

SERVICE MANUAL



Ver 1.4



ISSUE DATE: Apr. 24, 2019



- ▶ Please read the manual carefully and keep it in mind before using this machine.
- ▶ Put this manual within touch of your reference in anytime.

PRECAUTIONS FOR USE

The following safety precautions are given throughout this manual. They must be strictly followed to protect those who install, use or maintain this product as well as to protect players, visitors and property.

For safety reasons.

- The following suggestions should be adhered to:



Disregarding could result in serious injury.



Disregarding could result in injury or product damage.

- The following graphic suggestions describe the types of precautions to be followed.



Indicates a care should be taken.



Forbidden.



Indicates a matter which must be performed.

- **Precautions to be followed:**

Certain procedures require a qualified in-shop maintenance person or industry specialist.

For such instructions, a qualified person must take care of the jobs.

- Otherwise an electric shock, machine trouble or a serious accident may result.
- Replacing the machine parts, inspecting and maintaining the machines and troubleshooting must be assigned only to a qualified in-shop maintenance person or industry specialist. This booklet gives instructions that hazardous jobs in particular must be handled by an industry specialist. Qualified in-shop maintenance person and industry specialist are defined as follows.

Qualified in-shop maintenance person

- A service staff shall have experience in operations of game machines. The staff shall be responsible for assembly, installation, inspection and maintenance of the machine.

Industry specialist

- An industry specialist must be engaged in designing, manufacturing, inspecting and servicing amusement machines. He or she must have an education in electrical, electronic and mechanical engineering and routinely maintain and repair amusement machines.

PRECAUTIONS FOR USE

WARNING

Be sure to consult an industry specialist when setting up, moving or transporting this product.

- This product should not be set up, moved or transported by any one other than an industry specialist.
- When installing this product, set the 4 leg levelers evenly on the floor and make sure that the product is installed stably in a horizontal position. Unstable installation may result in injury or accident.
- When installing this product, do not apply undue force on movable parts. Otherwise, injury and accident may result, or the product may be damaged.

The machine for indoor usage only does not install outside.



Do not set the game machine up near emergency exits.



Protect the game machine from:

- Rain or moisture.
- Direct sunlight.
- Direct heat from air-conditioning and heating equipment, etc..
- Hazardous flammable substances.
- Otherwise an accident or malfunction may result.



Do not place containers holding chemicals or water on or near the game machine.



Do not place objects near the ventilating holes.



Do not bend the power cord by force or place heavy objects on it.



Never plug or unplug the power cord with wet hands.



Never unplug the game machine by pulling the power cord.



CAUTION

Be sure to use indoor wiring within the specified voltage requirements. For extension cord, use the specified rating or more.

Be sure to use the attached power cord.

Never plug more than one cord at a time into the electrical receptacle.



Do not lay the power cord where people walk through.



Be sure to ground this product.



Do not exert excessive force when moving the machine.



For proper ventilation, keep the game machine 100mm(4") away from the walls.

Do not alter the system related dipswitch settings.

PRECAUTIONS FOR USE

WARNING

If there is any abnormality such as smoke, bad smell or abnormal noise being emitted from the machine, immediately turn OFF the main power switch and unplug the power cord from the receptacle to stop operating it. 

- Using the machine in abnormal conditions could result in fire or accidents.

In case of abnormality

1. Turn OFF the main power switch.
2. Unplug the power cord from the receptacle.
3. Contact your nearest dealer.

Do not leave the power cord plugged in improperly or covered with dust. 

- Doing so could result the power cord periodically.

CAUTION

Do not use this product anywhere other than industrial areas. 

- Using in a residential area or an area next to a residential area could affect signal reception of radios, television sets, telephones and etc..
- Do not give shock the surface of glass products.

- Please do not play this game if
 - When you do drinking;
 - When your physical condition is not normal;
 - When you are in pregnancy;
 - When you have on a pulse controller;
 - When you have recently experienced a cramp or fainting away while watching TV.
- Avoid excessive force/shock while playing/moving the game.
- While do games, pay attention to surrounding.

Do not plug or unplug the power cord with wet hands. 

In handling the power cord, follow the instructions below. 

- | | |
|---|--|
| • Do not damage the power cord. | • Do not modify the power cord. |
| • Do not bend the power cord excessively. | • Do not twist the power cord. |
| • Do not heat the power cord. | • Do not pull the power cord. |
| • Do not bind the power cord. | • Do not stand on the power cord. |
| • Do not sandwich the power cord. | • Do not drive a nail into the power cord. |

If the power cord or power plug becomes damaged, stop using the machine immediately and ask your nearest dealer to replace the parts.

*** Electromagnetic wave may cause unexpected noise from speaker.**

PRECAUTIONS FOR USE

⚠ WARNING

Be sure to turn OFF the main power switch and unplug the power cord from the receptacle before inspecting or cleaning the machine.



When replacing parts, be sure to use parts of the correct specifications. Never use parts other than the specified ones.



Opening inside the machine shall be done by machine specialist only as high electric current is being sent inside. For game machine with monitor, a care should be taken while opening its back door. If not, a damage to the inside parts or the monitor may occur.



If the sub power switch of the service panel is turned OFF without turning OFF the main power switch of the power supply unit, some parts in the units remain live. When opening the back door, be sure to turn OFF the main power switch and unplug the power cord from the receptacle.



Strictly refrain from disassembly and repair of parts which are not indicated in this manual, as well as settings and remodeling.



To clean the game machine, wipe it with a soft cloth dampened in a neutral detergent.

- Using thinner or other organic solvent or alcohol may decompose the material.
- Electrical shock or equipment failure could be caused by water entering the inside of the machine.

⚠ CAUTION

Components in the game are sensitive to vibrations and impact. Care should be used when moving and transporting the game machine.



Be sure not to let the machine tip over.

Before moving the machine, be sure to turn OFF the main power switch, unplug the power cord from the receptacle and remove the power cord from the machine.



Before moving take the machine, off the levelers and move it on the casters.

Avoid excessive force while moving the machine.

.....

PRECAUTIONS IN HANDLING

- When setting up, inspecting, maintaining, moving or transporting this product, follow the procedures and instructions set forth in this manual and perform such work safely.
- Do not set up, handle, inspect, maintain, move or transport this product under conditions equivalent to the condition of "WARNING" or "CAUTION" specified in this manual.
- If a new owner is to have this product as a result of transfer, and etc., be sure to give this manual to the new owner.

PRÉCAUTION D'EMPLOI

Les consignes de sécurité suivantes sont données dans ce manuel. Elles doivent être strictement suivies pour protéger ceux qui les installent. Utiliser ou entretenir ce produit pour la sécurité des utilisateurs, des visiteurs et des biens.

Pour des raisons de sécurité.

- **Les suggestions suivantes doivent être respectées:**

ATTENTION

Le non-respect peut entraîner des blessures graves.

PRUDENCE

Le non-respect peut entraîner des blessures ou des dommages au produit.

- **Les suggestions graphiques suivantes décrivent les types de précautions à prendre.**



Indique qu'attention est requise.



Interdit.



Indique que quelque chose doit être effectuée.

- **Les précautions à prendre :**

Certaines procédures exigent une personne de maintenance qualifiée en atelier ou un spécialiste de l'industrie. Pour ces instructions, une personne qualifiée doit prendre soin des travaux.

- Sinon, un choc électrique, un dysfonctionnement de la machine, ou un accident grave peut en résulter.
- Remplacement des pièces de machines, l'inspection et la maintenance des machines, et le dépannage doit être attribué qu'à une personne de maintenance qualifiée en atelier ou spécialiste de l'industrie. Cette brochure donne des instructions que les emplois dangereux, en particulier, doivent être traités par un spécialiste de l'industrie. La personne de maintenance qualifiée en atelier et le spécialiste de l'industrie sont définis comme suit.

La personne de maintenance qualifiée en atelier

- Un personnel de service doit avoir de l'expérience dans les opérations de machines de jeux. Le personnel est responsable pour l'assemblage, l'installation, l'inspection et l'entretien de la machine.

Le spécialiste de l'industrie

- Un spécialiste de l'industrie doit être engagé dans la conception, la fabrication, l'inspection et l'entretien des appareils d'amusement.
Il ou elle doit avoir une formation en génie électrique, électronique et mécanique, et de maintenir régulièrement et de réparer les appareils d'amusement.

PRÉCAUTION D'EMPLOI

ATTENTION

Si il y a une anomalie comme fumée, mauvaise odeur ou bruit anormal émis par la machine,  couper immédiatement l'interrupteur principal et débranchez le câble d'alimentation de la prise pour arrêter son fonctionnement.

- L'utilisation de l'appareil dans des conditions anormales peut provoquer un incendie ou un accident.

En cas d'anomalie

1. Mettez l'interrupteur principal sur ARRÊT.
2. Débranchez le câble d'alimentation de la prise.
3. Contactez votre revendeur le plus proche.

Ne pas brancher le câble d'alimentation incorrectement ou le laisser être recouvert de poussière. 

Cela pourrait nuire le câble d'alimentation.

PRUDENCE

Ne pas utiliser ce produit ailleurs que dans les zones industrielles. 

- L'utiliser dans une zone résidentielle ou d'une zone à côté d'un quartier résidentiel pourrait nuire à la réception des radios, téléviseurs, téléphones, etc.
- Ne donnez pas de choc à la surface d'un produit en verre.

- S'il vous plaît ne pas jouer à ce jeu.
 - Quand vous buvez;
 - Lorsque votre condition physique n'est pas normale;
 - Lorsque vous êtes dans une période de grossesse;
 - Lorsque vous avez un contrôleur d'impulsion;
 - Lorsque vous avez récemment subi une crampe ou évanouissement en regardant la télévision.
- Évitez une force excessive / un choc pendant la lecture / de déplacer le jeu.
- Quand vous jouez les jeux, faites attention aux alentours.

Ne pas brancher ou débrancher le câble d'alimentation avec les mains mouillées. 

Dans la manipulation du câble d'alimentation, suivez les instructions ci-dessous. 

- | | |
|--|---|
| • Ne pas endommager le câble d'alimentation. | • Ne pas modifier le câble d'alimentation. |
| • Ne pas plier le câble d'alimentation de manière excessive. | • Ne tordez pas le câble d'alimentation. |
| • Ne pas chauffer le câble d'alimentation. | • Ne tirez pas sur le câble d'alimentation. |
| • Ne pas lier le câble d'alimentation. | • Ne montez pas sur le câble d'alimentation. |
| • Ne pas prendre en sandwich le câble d'alimentation. | • Ne pas mettre un clou dans le câble d'alimentation. |

Si la fiche du câble d'alimentation ou est endommagé, cessez immédiatement d'utiliser la machine et demandez à votre revendeur le plus proche de remplacer les pièces.

PRÉCAUTION D'EMPLOI

⚠ ATTENTION

Assurez-vous de consulter un spécialiste de l'industrie lors de la mise en place, du déplacement ou le transport de ce produit.

- Ce produit ne doit pas être mis en place, déplacé ou transporté par une quelconque autre qu'un spécialiste de l'industrie.
- Lors de l'installation de ce produit, installez 4 niveleurs de pieds uniformément sur le sol et assurez-vous que le produit est installé de façon stable dans une position horizontale. Une installation instable peut entraîner des blessures ou un accident.
- Lors de l'installation de ce produit, ne pas appliquer une force excessive sur les pièces mobiles. Sinon, des blessures et des accidents peuvent y résulter, ou le produit peut être endommagé.

La machine pour une utilisation en intérieur uniquement, ne pas installer à l'extérieur.



N'installez pas la machine de jeu près des issues de secours.



Protéger la machine de jeu de:



- L'humidité ou la pluie.
- La lumière directe du soleil.
- La chaleur directe de la climatisation et du chauffage, etc...
- Des substances inflammables dangereuses.
- Sinon, un accident ou un dysfonctionnement.

Ne pas placer les récipients contenant des produits chimiques ou de l'eau sur ou près de la machine de jeu.



Ne placez pas d'objets à proximité des orifices de ventilation.



Ne pas plier le cordon d'alimentation par la force ou de placer des objets lourds au-dessus.



Ne jamais brancher ou débrancher le cordon d'alimentation avec les mains mouillées.



Ne jamais débrancher la machine de jeu en tirant le câble d'alimentation.



⚠ PRUDENCE

Veillez à utiliser le câblage intérieur selon les exigences de tension spécifiées. Pour une rallonge, utilisez la notation spécifiée ou plus.

Veillez à utiliser le cordon d'alimentation fourni.

Ne jamais brancher plus d'un cordon à la fois dans la prise électrique.



Ne pas poser le cordon d'alimentation où les gens marchent à travers.



Soyez sûr de mettre à la terre ce produit.



Ne pas exercer une force excessive lors du déplacement de la machine.





Pour une ventilation correcte, garder la machine de jeu 100mm (4 ") loin des murs.

Ne pas modifier les réglages des commutateurs DIP liées au système.

PRÉCAUTION D'EMPLOI

ATTENTION

Veillez à éteindre l'interrupteur d'alimentation principale et débranchez le cordon d'alimentation de la prise avant d'inspecter ou de nettoyer la machine. 

Lors du remplacement des pièces, veillez à utiliser une partie des spécifications correctes. Ne jamais utiliser de pièces autres que celles spécifiées. 

L'ouverture à l'intérieur de la machine doit être effectuée par le spécialiste de la machine seulement, comme le courant électrique élevé est transmis à l'intérieur. Pour la machine de jeu avec le moniteur, un soin doit être pris lors de l'ouverture de sa porte arrière. Si non, une détérioration des pièces à l'intérieur ou à l'écran peut se produire. 

Si l'interrupteur secondaire du panneau de service est éteint sans éteindre le commutateur d'alimentation principale de l'unité d'alimentation, certaines parties dans les unités restent sous tension. Lors de l'ouverture de la porte arrière, veillez à éteindre l'interrupteur d'alimentation principale et débranchez le cordon d'alimentation de la prise. 

Il est strictement conseillé de s'abstenir de démonter et de réparer des pièces qui ne sont pas indiqués dans ce manuel, ainsi que les paramètres et le remodelage. 

Pour nettoyer la machine de jeu, l'essuyer avec un chiffon doux imbibé avec un détergent neutre.

- L'utilisation plus mince d'un autre solvant organique ou de l'alcool peut décomposer le matériel.
- Un choc électrique ou une défaillance de l'équipement pourraient être causés par la pénétration de l'eau à l'intérieur de la machine.

PRUDENCE

Les composants de la machine de jeu sont sensibles aux vibrations et aux chocs. Il faut faire attention lors du déplacement et le transport de la machine de jeu. 

Veillez à ne pas laisser la machine se renverser.

Avant de déplacer la machine, veillez à éteindre l'interrupteur d'alimentation principale, débranchez le cordon d'alimentation de la prise et débranchez le cordon d'alimentation de la machine. 

Avant de déplacer la machine, la mettre hors des niveleurs et le déplacer sur les roulettes.

Éviter une force excessive lors du déplacement de la machine.

.....

PRÉCAUTIONS LORS DU MANIEMENT

- Lors de la mise en place, l'inspection, l'entretien, déplacement ou le transport de ce produit, suivez les procédures et les instructions énoncées dans ce manuel et effectuer ce travail en toute sécurité.
- Ne pas mettre en place, manipuler, inspecter, entretenir, déplacer ou transporter ce produit dans des conditions équivalentes à l'état de "ATTENTION" ou "PRUDENCE" spécifiée dans ce manuel.
- Si un nouveau propriétaire obtient ce produit à la suite d'un transfert, etc., soyez sûr de donner ce manuel au nouveau propriétaire.

CONTENTS

1. SPECIFICATION AND DIMENSION	P03
1-1. DIMENSION	P03
1-2. SPECIFICATION	P03
1-3. NAME OF PARTS	P04
1-4. STICKER LOCATION	P05
1-5. COMPONENTS	P06
2. INSTALLATION	P07
2-1. INSTALLATION SPACE	P07
2-2. HOW TO INSTALL	P08
3. GAME CHARACTERISTICS	P09
4. SETUP SETTINGS	P10
4-1. MACHINE SETUP	P10
4-1-1. IO TEST	P11
4-1-2. GAME SETTING	P15
4-1-3. CREDIT SETTING	P17
4-1-4. TICKET SETTING	P18
4-1-5. SOUND SETTING	P20
4-1-6. BOOKKEEPING	P21
4-1-7. STATISTICS	P22
4-1-8. SYSTEM UPDATE	P25
4-1-9. FACTORY SETTING	P27
4-2. ERROR CODE	P28
5. TROUBLESHOOTING	P29
5-1. MONITOR ERROR	P29
5-2. GAME BUTTON LED PCB ERROR	P30
5-3. THE LED IS MALFUNCTION FROM CONTROLLER SIDE LED PCB	P31
5-4. WS2813B FLEX LED ERROR	P33
5-5. FRONT, REAR ENCODER ERROR [E3-01]	P35
5-6. VIBRATOR MOTOR ERROR	P37
5-7. COIN SELECTOR ERROR [E1-01]	P39

5-8. TICKET DISPENSER ERROR [ET-01]	P41
5-9. COUNTER ERROR	P42
5-10. SETUP BUTTON ERROR	P43
5-11. SOUND ERROR	P44
6. EXPLODED VIEW	P46
6-1. MAIN CABINET PART	P46
6-2. BILLBOARD PART	P47
6-3. MONITOR FRONT COVER PART	P48
6-4. SPEAKER & MONITOR DECO FPAME PART	P49
6-5. TABLE PANEL PART	P50
6-6. SMPS PART	P51
6-7. SERVICE PANEL PART	P52
6-8. TICKET DISPENSER PART	P52
6-9. FRONT DOOR PART	P53
6-10. COIN BOX PART	P53
6-11. MAIN BOX PART	P54
6-12. CABINET PCB PART	P54
7. PART PICTURE	P55
8. BLOCK DIAGRAM	P56

1. SPECIFICATION AND DIMENSION

1-1. DIMENSION

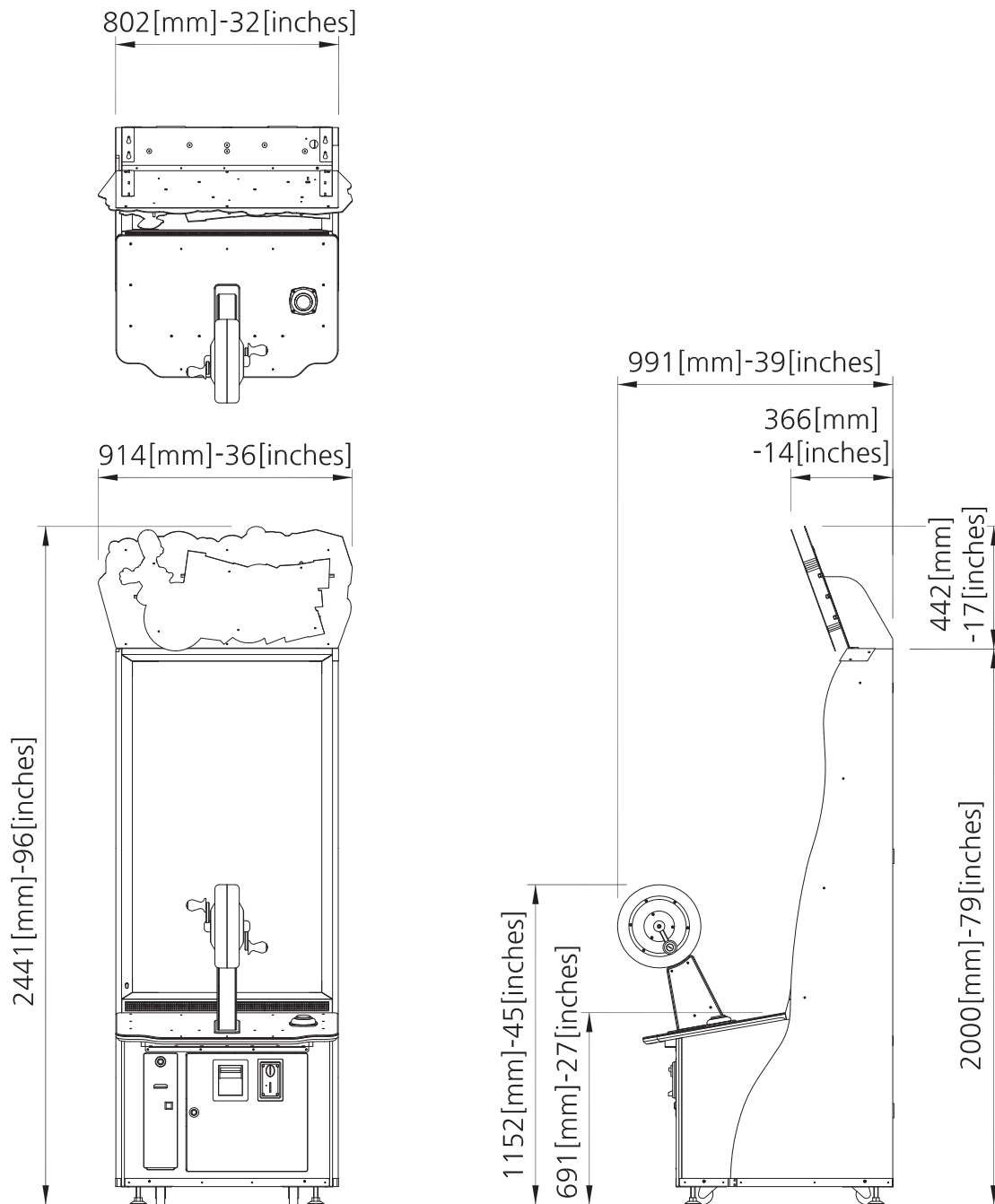

1-2. SPECIFICATION

DIMENSION (W x D x H)	802 x 991 x 2348 (mm)
PACKING DIMENSION (W x D x H)	1150 x 910 x 2160 (mm)
WEIGHT (kg)	160 kg [WEIGHT INCLUDING : 240 kg] PACKAGING]
VOLTAGE	AC 120V
FREQUENCY RANGE	60Hz
CONSUMPTION	360 W
CERTIFICATION	-

* The 120V voltage specification is for the Americas only, and the 230V (50/60Hz) voltage specification is for other regions.

1-3. NAME OF PARTS

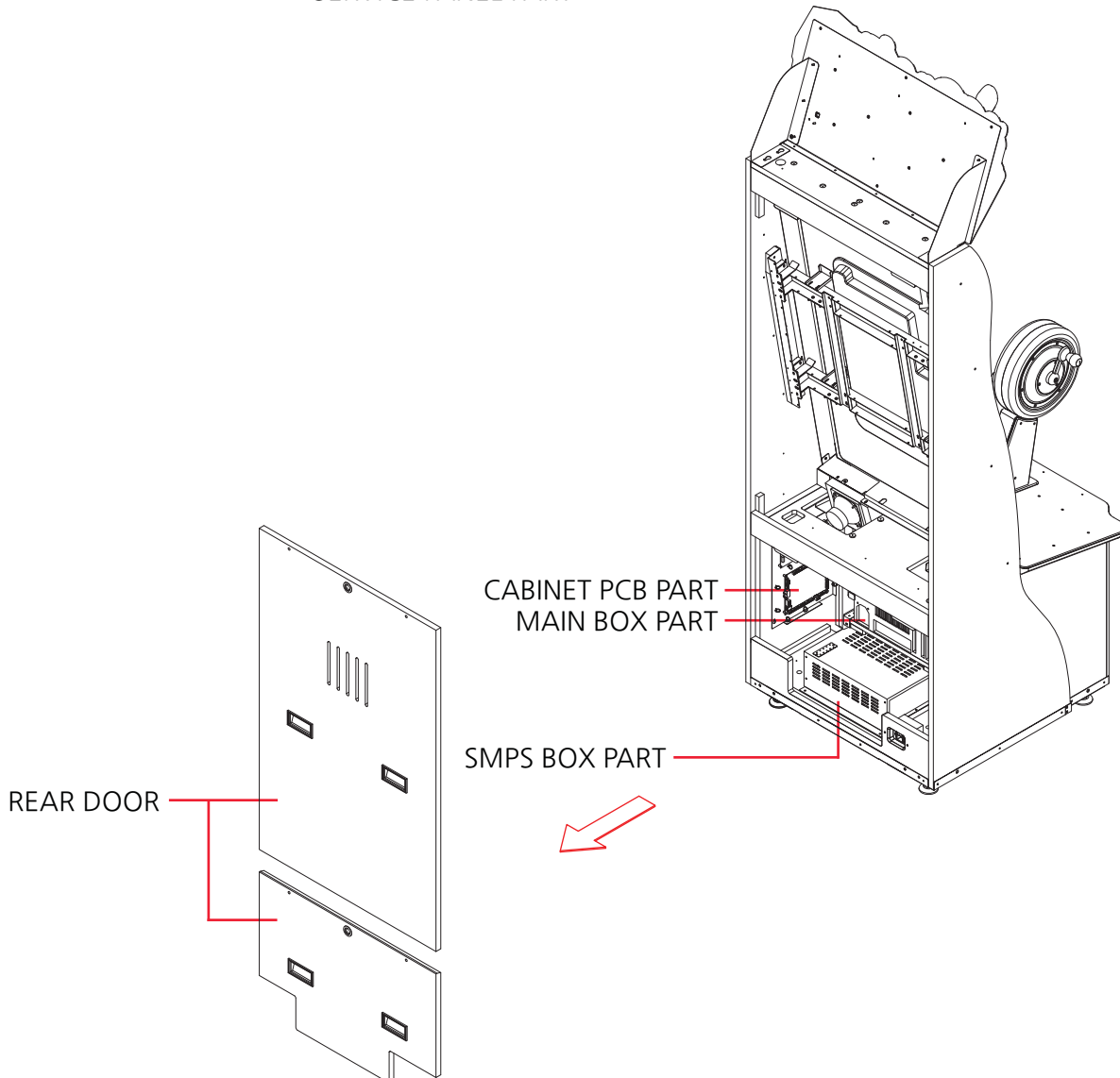
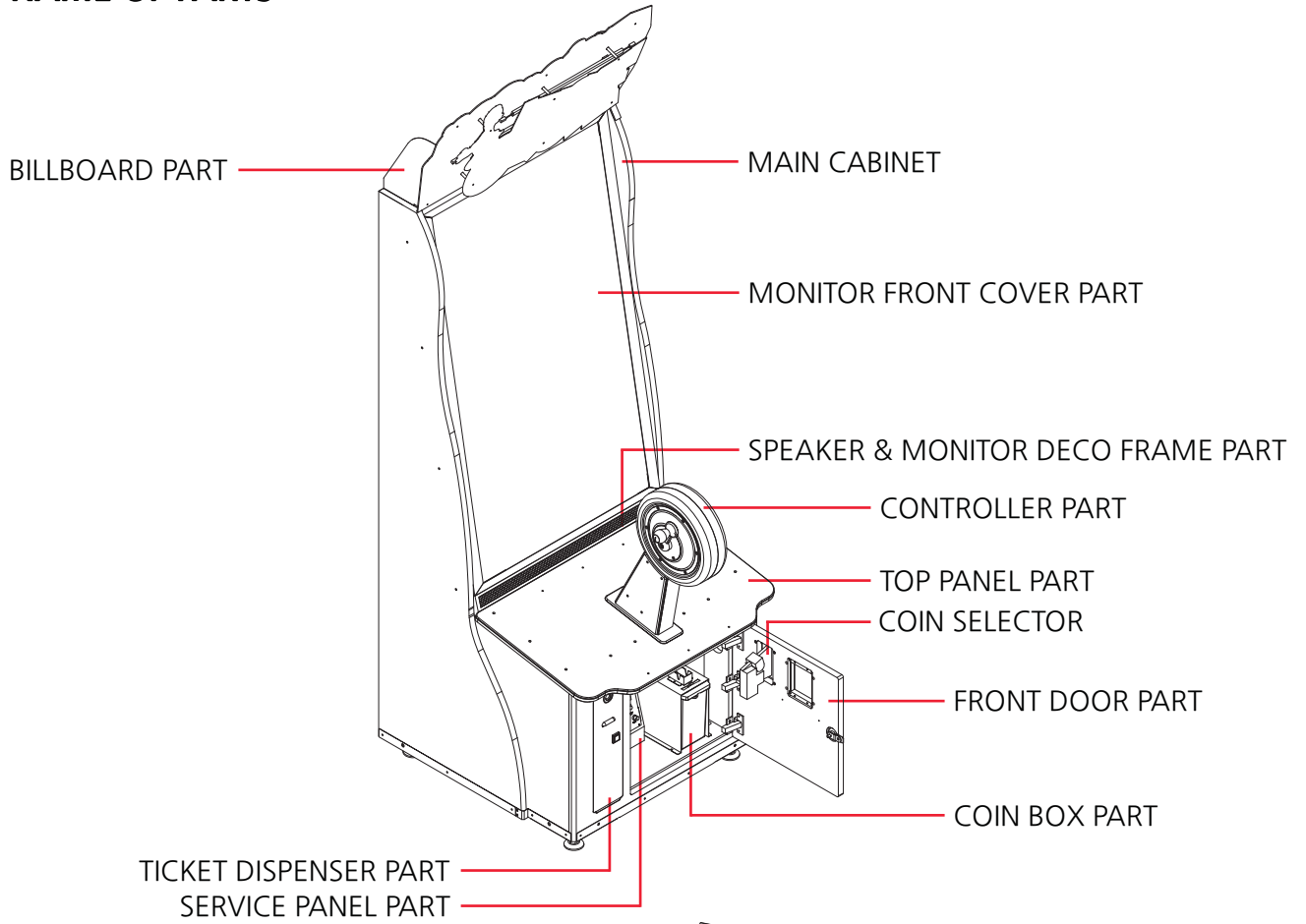

1-4. STICKER LOCATION

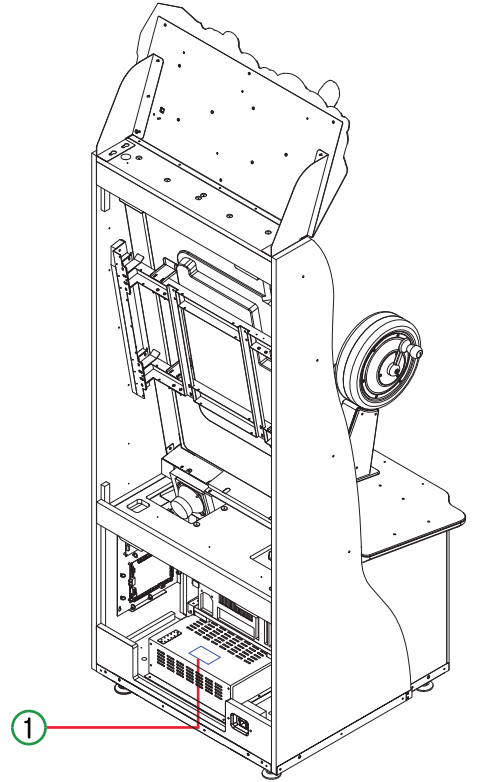
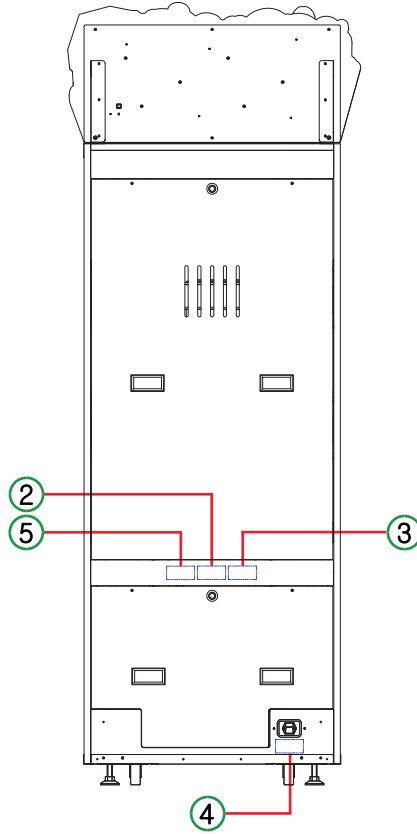
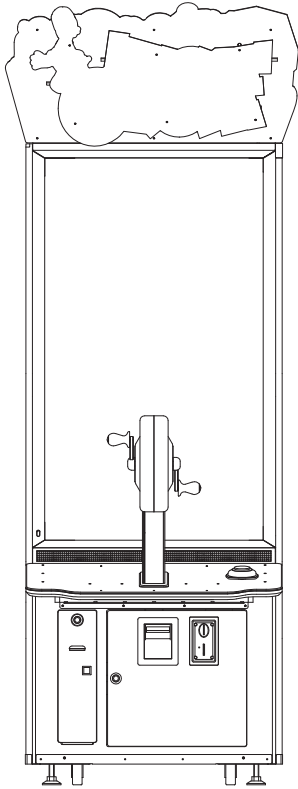

1

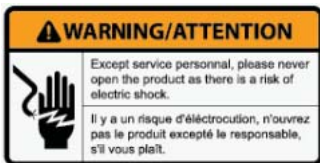

2



3

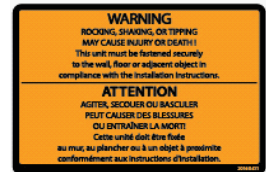



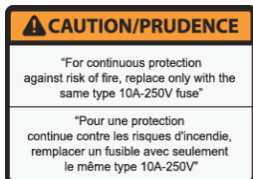



4

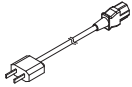

5

Certification Label

1-5. COMPONENTS

NO.	PART NAME	SPEC.	QTY
1	AC POWER CORD	- 	1
2	KEY	6001 	2
3	KEY	7001 	2
4	BOLT	4x8L 	6
5	BOLT	4x14L 	2
6	BOLT	6x25L 	6
7	NUT	M4 	8
8	WRENCH	2.5, 3, 4, 6MM 	1 EACH
9	COIN SELECTOR BLANK BKT	- 	1
10	MANUAL	- 	1
11	TROUBLESHOOTING MANUAL	- 	1

2. INSTALLATION

2-1. INSTALLATION SPACE

- Need to have installation place.
Maintenance zone & Play zone should have at least 2000mm x 2000mm each.

***IMPORTANT**

- Once you set up the machine with required game-play area, when installing this product, set the 4 leg levelers evenly on the floor and make sure that the product is installed stably in a horizontal position. Otherwise the set winning percentage can be twisted.

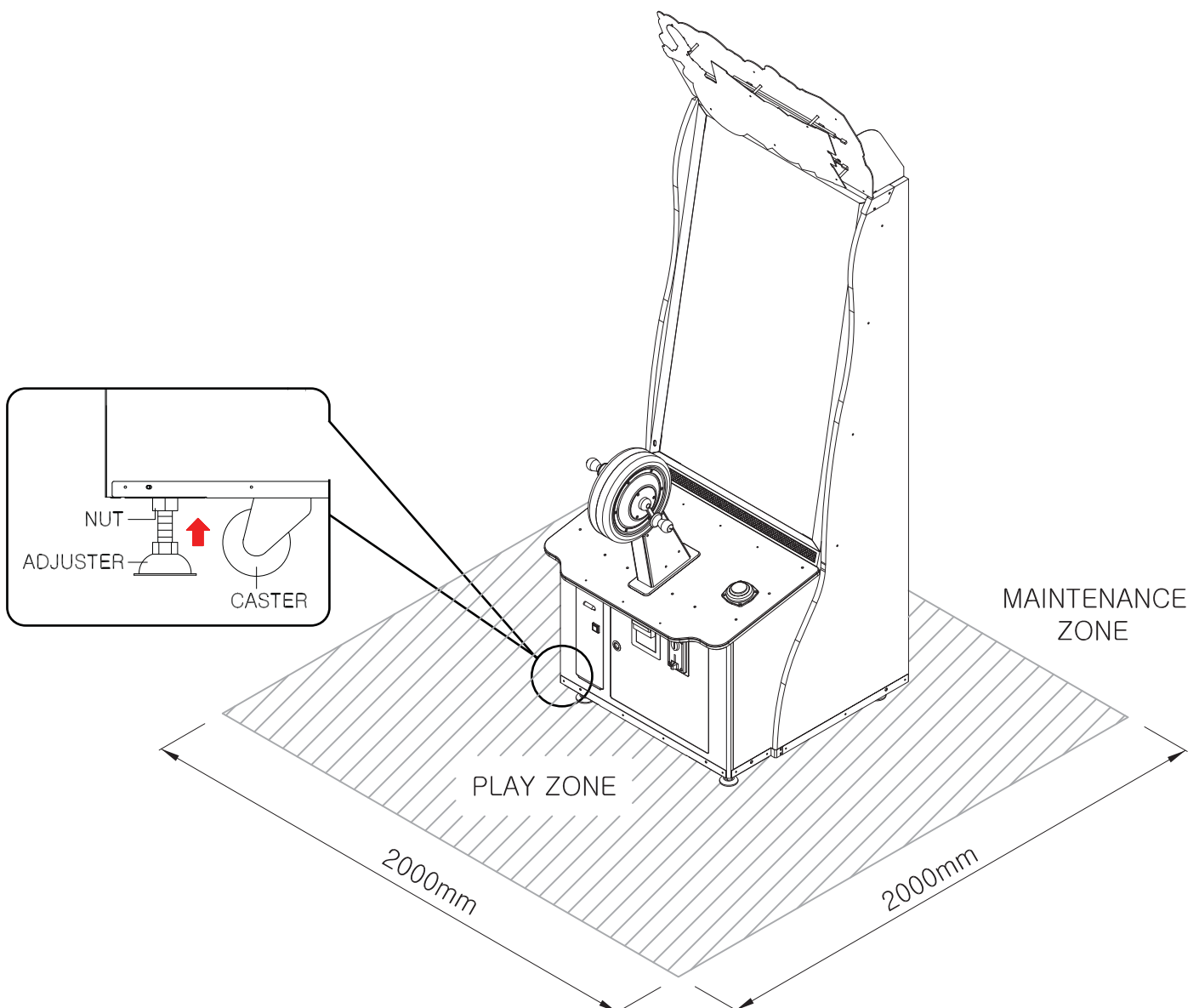

2-2. HOW TO INSTALL

1

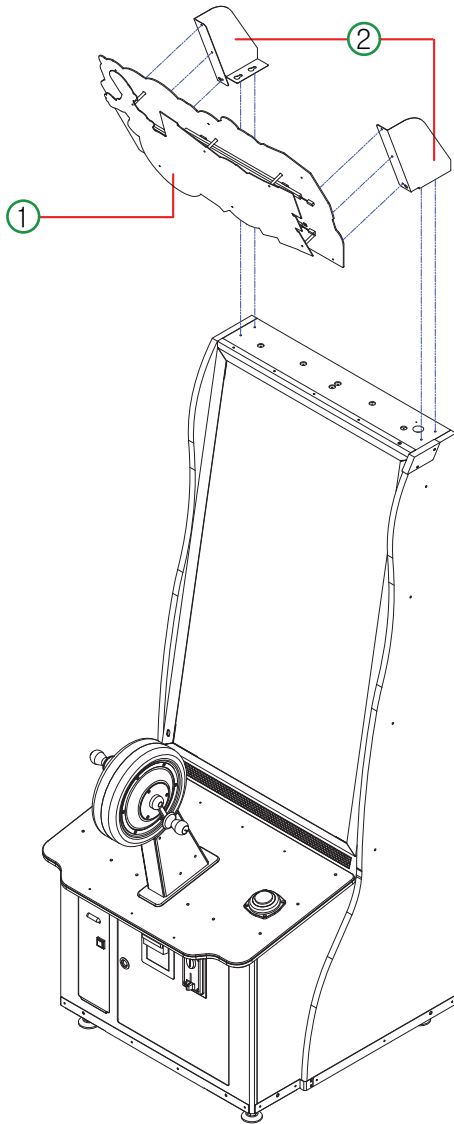

- After assembling ① BILLBOARD FRAME PART and ② BILLBOARD FIX BKT L, R, connect connector using [M6 bolts, 4pcs]

2



- You complete it like picture.

3. GAME CHARACTERISTICS

* RUN AWAY FROM CHASER AND ACROSS TIGHT ROPE !!

- *You can feel the vibration through the controller*
- *Enjoy our marvelous 3 stages*
- *Overcome thrill and tension by chaser & obstacles and get into the goal to get a Super bonus!*

Easy & Unique Controller



4. SETUP SETTINGS

4-1. MACHINE SETUP

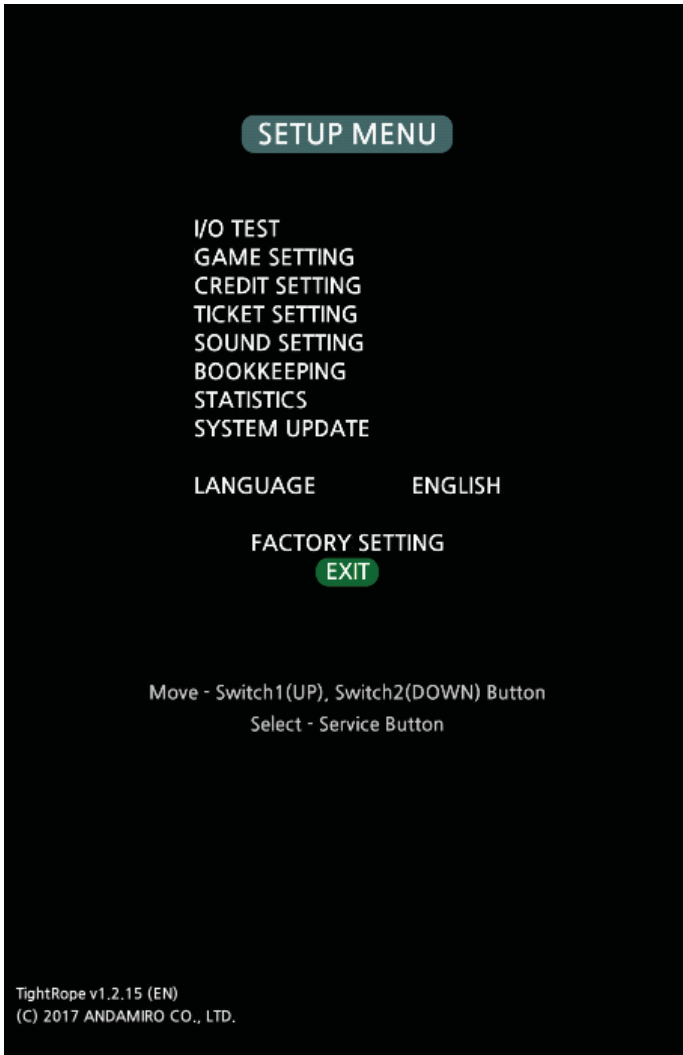

- I/O TEST : TEST INPUT, OUTPUT SYSTEM and SCREEN COLOR. Enter to 'I/O TEST' Page.
- GAME SETTING : SET UP GAME SETTING. Enter to 'GAME SETTING' Page.
- CREDIT SETTING : SET UP CREDIT SETTING. Enter to 'CREDIT SETTING' Page.
- TICKET SETTING : SET UP TICKET SETTING. Enter to 'TICKET SETTING' Page.
- SOUND SETTING : SET UP SOUND SETTING. Enter to 'SOUND SETTING' Page.
- BOOKKEEPING : Check operation hours, play hours and etc. of machine. Enter to 'BOOKKEEPING' Page.
- STATISTICS : Check statistics of the entered coins and the emitted tickets. Enter to 'STATISTICS' Page.
- SYSTEM UPDATE : SYSTEM UPDATE. Enter to 'SYSTEM UPDATE' Page.

- LANGUAGE : SET THE GAME LANGUAGE.

SEQUENCE	ITEM	DESCRIPTION
1	ENGLISH	ENGLISH (DISTANCE UNIT : m)
2	ENGLISH(ft)	ENGLISH (DISTANCE UNIT : ft)
3	KOREAN	KOREAN (DISTANCE UNIT : m)

- FACTORY RESET : Reset all settings to default. Enter to 'FACTORY RESET' Page.
- EXIT

4-1-1. IO TEST

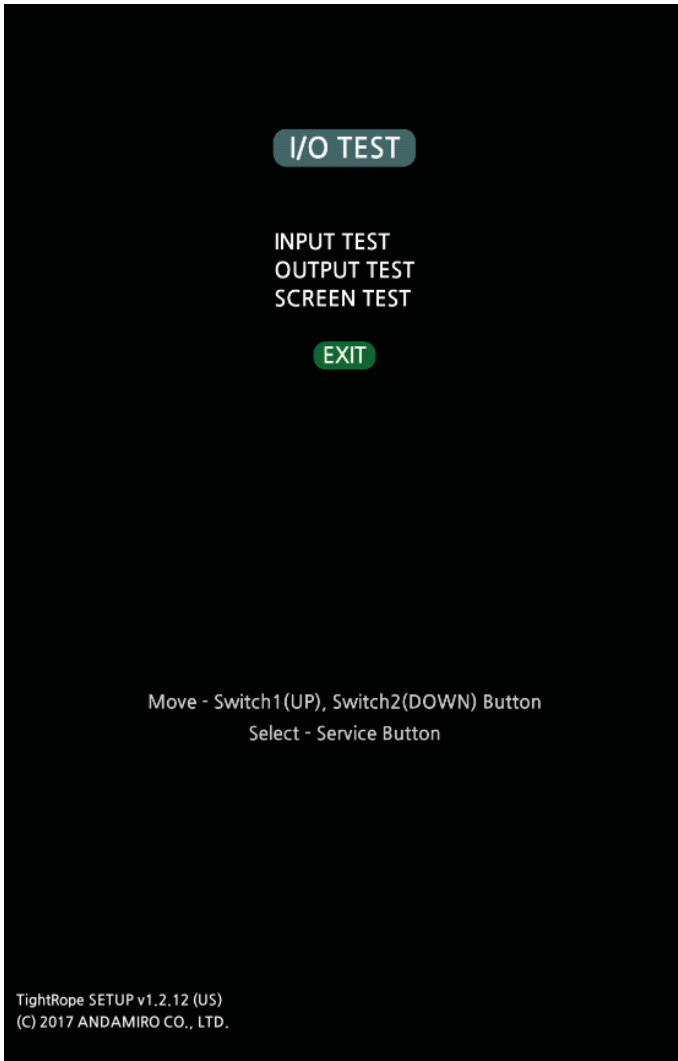

- INPUT TEST : Enter to test such as wheel controller, start button and etc. of inputs.
- OUTPUT TEST : Enter to test such as ticket dispenser, lighting, counter and etc. of outputs.
- SCREEN TEST : Enter to test such as display resolution, density, brightness, color representation and etc. of screen.
- EXIT : EXIT 'I/O TEST', then, Enter to 'MAIN SETUP MENU' Page.

[INPUT TEST]

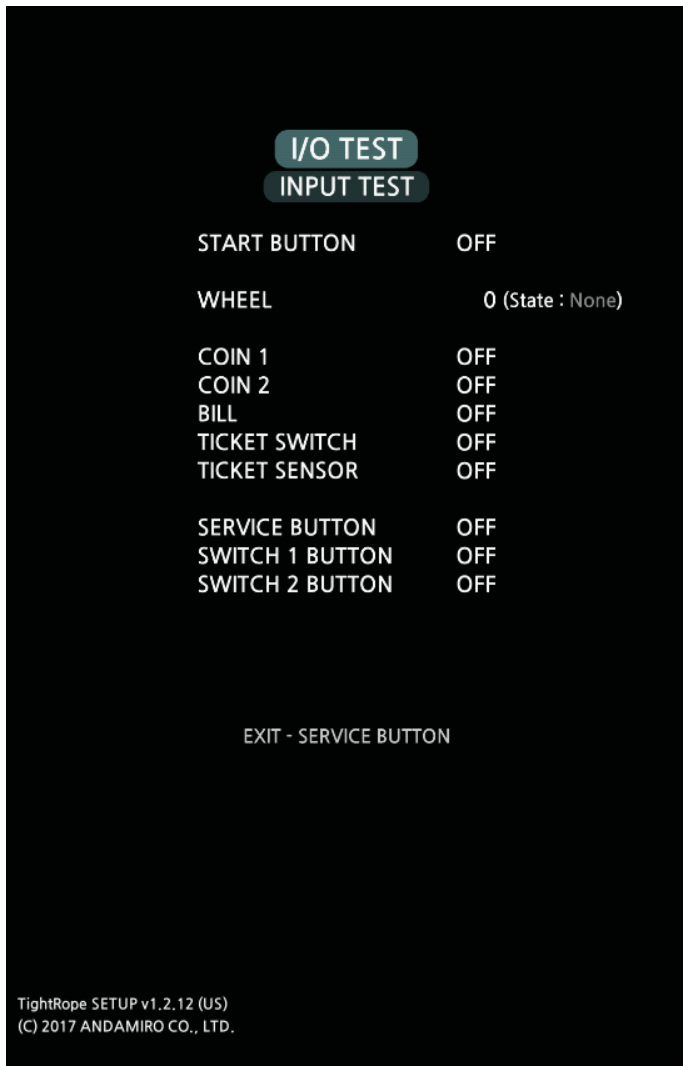

- START BUTTON : TEST "START BUTTON".
Displayed as ' ON ' when receiving input.

- WHEEL : Display acceleration and deceleration speed(zero based).
Display speed value to zero(0) when stationary.

Display speed value '+' when turning forward in advance,
max speed output to '+ 255'.

Display speed value '-' when turning reverse direction,
max speed output to '- 255'.

* Display wheel encoder sensor status when you turn wheel.

STATUS	DESCRIPTION
(State : None)	Not yet turn the wheel or no signal when you turn the wheel.
(State : F:OK, R:OK)	Front Sensor : Signal O, Rear Sensor : Signal O
(State : F:NG, R:OK)	Front Sensor : Signal X, Rear Sensor : Signal O
(State : F:OK, R:NG)	Front Sensor : Signal O, Rear Sensor : Signal X

- COIN 1/2 : TEST COIN 1 / COIN 2 INSERT. Displayed as ' ON ' when receiving input.

- BILL : TEST BILL INSERT. Displayed as ' ON ' when receiving input.

- TICKET SWITCH : TEST TICKET SWITCH BUTTON next to ticket dispenser.
Displayed as ' ON ' when receiving input.

- TICKET SENSOR : TEST TICKET SENSOR.
Displayed as ' ON ' when sensor was recognized.

- SERVICE BUTTON : TEST SERVICE BUTTON.
Displayed as ' ON ' when receiving input, then return to 'I/O TEST' MAIN Page.

- SWITCH 1 / 2 BUTTON : TEST SWITCH 1 / 2 BUTTON.
Displayed as ' ON ' when receiving input.

[OUTPUT TEST]

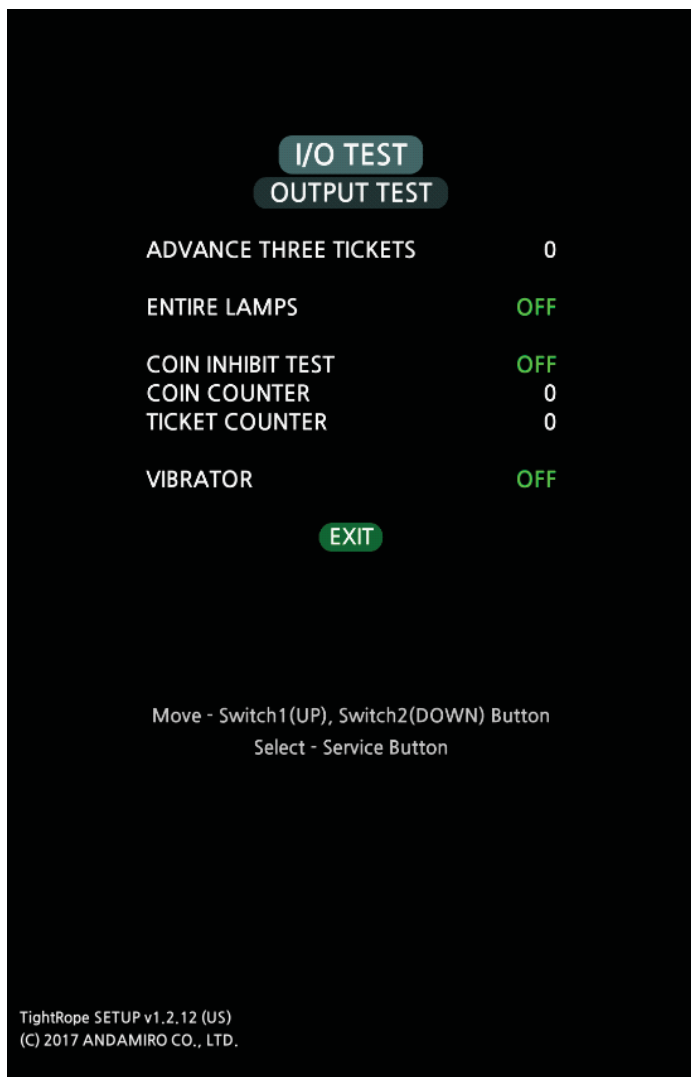

- ADVANCE THREE TICKETS : Ticket release test.
Release Three(3) tickets.
- ENTIRE LAMPS : TEST WHEEL CONTROLLER LIGHT AND START BUTTON ROUND LIGHT.
(Lighting Pattern : OFF -> Red -> Yellow -> Green -> Cyan -> Blue -> Magenta -> White (Repetition))
- COIN INHIBIT TEST : TEST INHIBIT OF COIN
(ON : Coin machine on,
OFF : Coin machine off)
- COIN COUNTER : When it was selected,
add 1 count of the coin counter.
- TICKET COUNTER : When it was selected,
add 1 count of the ticket counter.
- VIBRATOR : Test to Vibration Function
of wheel Controller.
- EXIT : EXIT 'OUTPUT TEST'.
Then, Enter to 'I/O TEST' MAIN Page.

[SCREEN TEST]

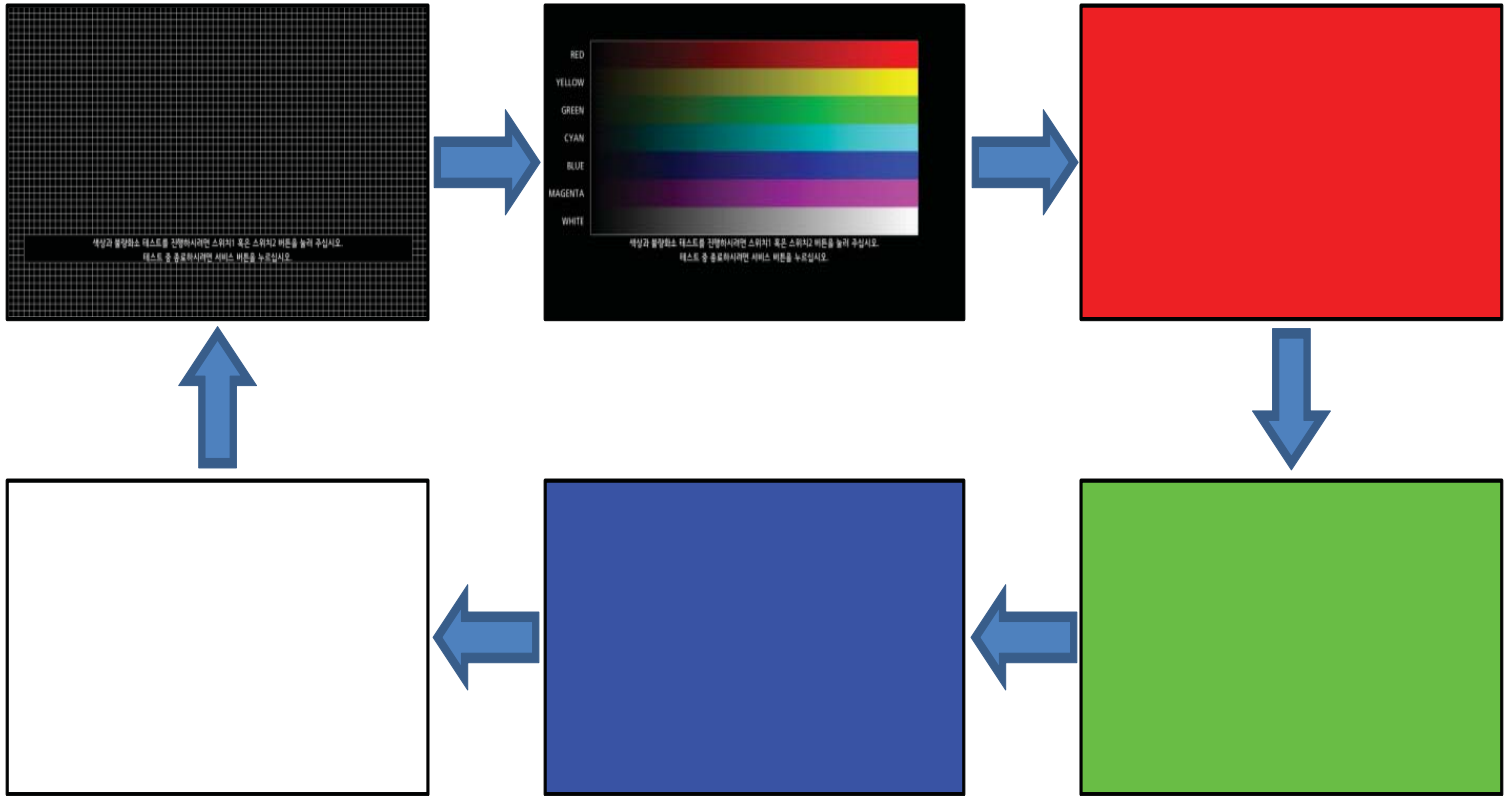

- TEST COLOR DISPLAY & POOR PIXELS ON THE MONITOR.

4-1-2. GAME SETTING

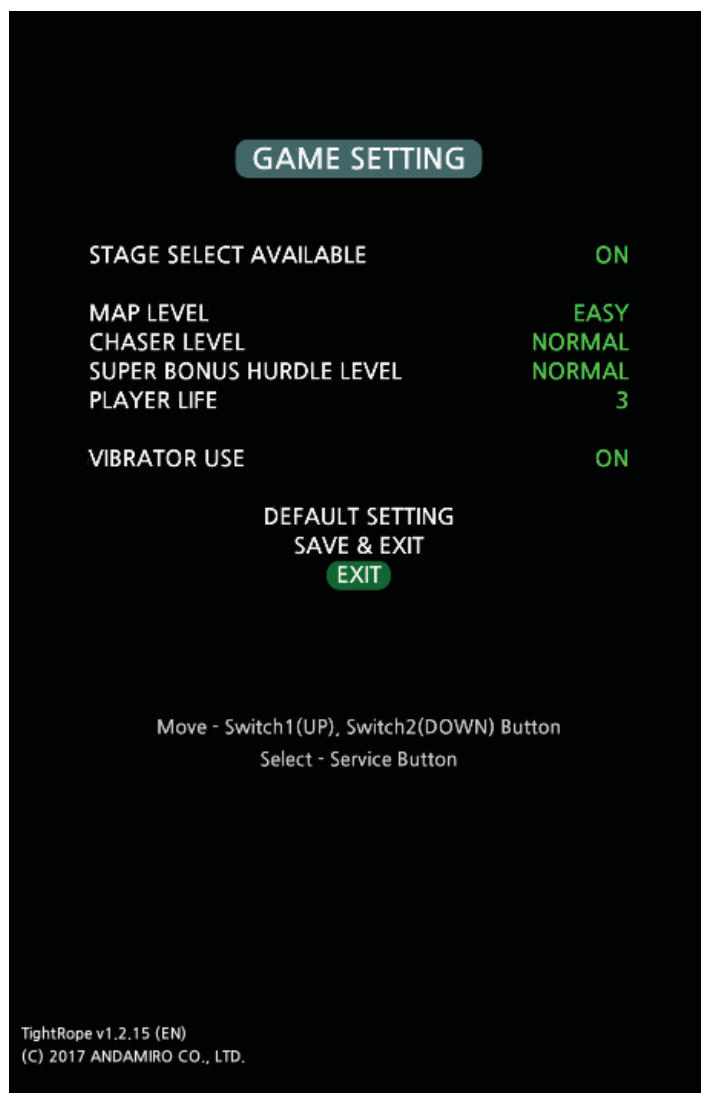

- STAGE SELECT AVAILABLE : Display 'Wallpaper Select' page, to set that player whether or not to select.

SEQUENCE	ITEM	DESCRIPTION
1	ON	Display 'Wallpaper Select' Page, then game will be proceed set set wallpaper by player .
2	OFF	Hide 'Wallpaper Select' Page, then game will be proceed with same wallpaper with title page.

- MAP LEVEL : SET UP the levels of difficulty by controlling the type of the maps.

SEQUENCE	ITEM	DESCRIPTION
1	EASY	Set up to EASY MAP
2	NORMAL	Set up to NORMAL MAP

- CHASER LEVEL : SET UP the levels of difficulty by controlling the speed of the chaser.

SEQUENCE	ITEM	VALUE
1	EASY	85% of default setting
2	NOMAL	Default setting
3	DIFFICULT	115% of default setting

- SUPER BONUS HURDLE LEVEL : SET UP the speed level of Super Bonus Hurdle.
SET UP difficulty of Super Bonus Hurdle speed.

SEQUENCE	ITEM	VALUE
1	EASY	85% of default setting
2	NOMAL	Default setting
3	DIFFICULT	115% of default setting

- PLAYER LIFE : SET UP No. of Player's lifes.

SEQUENCE	NO. OF LIFE
1	1
2	2
3	3
4	4
5	5

- VIBARATOR USE : SET UP using the Vibrator.

SEQUENCE	ITEM	DESCRIPTION
1	ON	USE the vibrator of wheel controlor
2	OFF	Do not use the vibrator of wheel controlor

- DEFAULT SETTING : 'Reset 'GEME SETTING' to Default setting.
- SAVE & EXIT : Save the changed setting and Enter to the 'MAIN SETUP MENU' Page.
- EXIT : Do not save the changed setting and Enter to the 'MAIN SETUP MENU' Page.

4-1-3. CREDIT SETTING

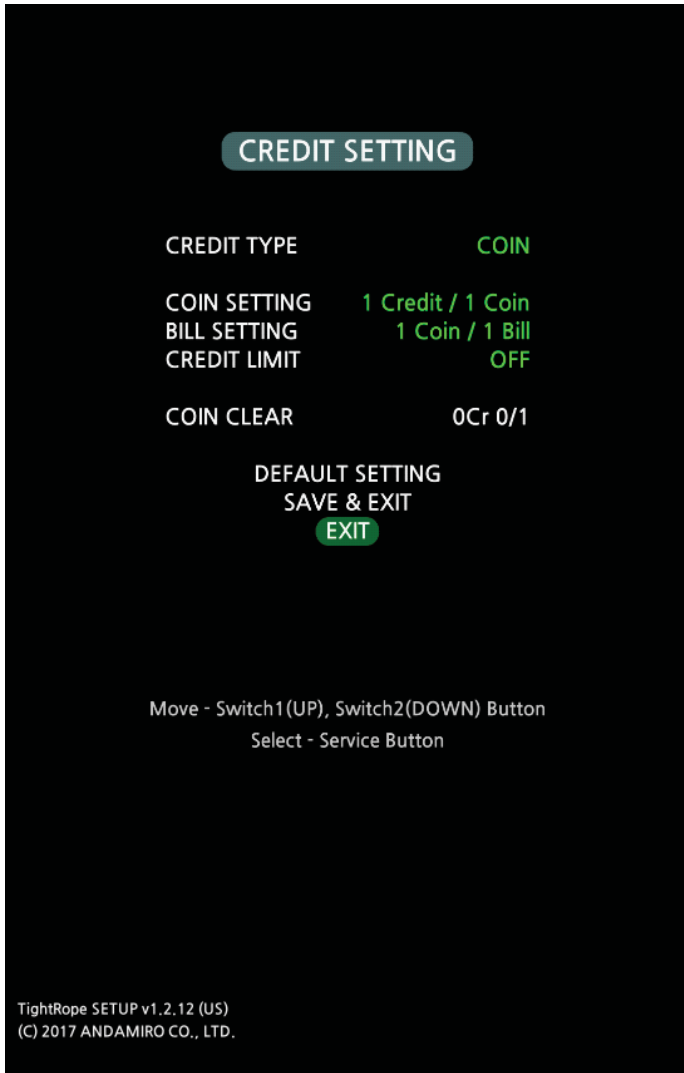

- CREDIT TYPE : SET UP type of payment -
Set up to display type of credit.

SEQUENCE	ITEM	DISPLAY
1	COIN(S)	INSERT COIN(S)
2	CARD(S)	SWIPE CARD(S)

- COIN SETTING : SET UP coin setting.

SEQUENCE	DESCRIPTION
1	SET 1 Credit / 1 Coin
2	SET 1 Credit / 1 Coin
~	~
17	SET 9 Credit / 1 Coin
18	SET to Free Play

- BILL SETTING : SET UP bill setting.

SEQUENCE	DESCRIPTION
1	1 Coin / 1 Bill
2	2 Coin / 1 Bill
~	~
10	10 Coin / 1 Bill

- CREDIT LIMIT : SET UP Credit Limit.

SEQUENCE	DESCRIPTION
1	OFF
2	1 Credit
3	2 Credit
~	~
10	9 Credit
11	10 Credit

- COIN CLEAR : Clear credit for the coin and credit inserted.
On the right side of the Menu, Displays the current Credit.

- DEFAULT SETTING : Reset 'Credit Setting' to factory setting.

- SAVE & EXIT : Save the changed setting and Enter to the 'MAIN SETUP MENU' Page.

- EXIT : Do not save the changed setting and Enter to the 'MAIN SETUP MENU' Page.

4-1-4. TICKET SETTING

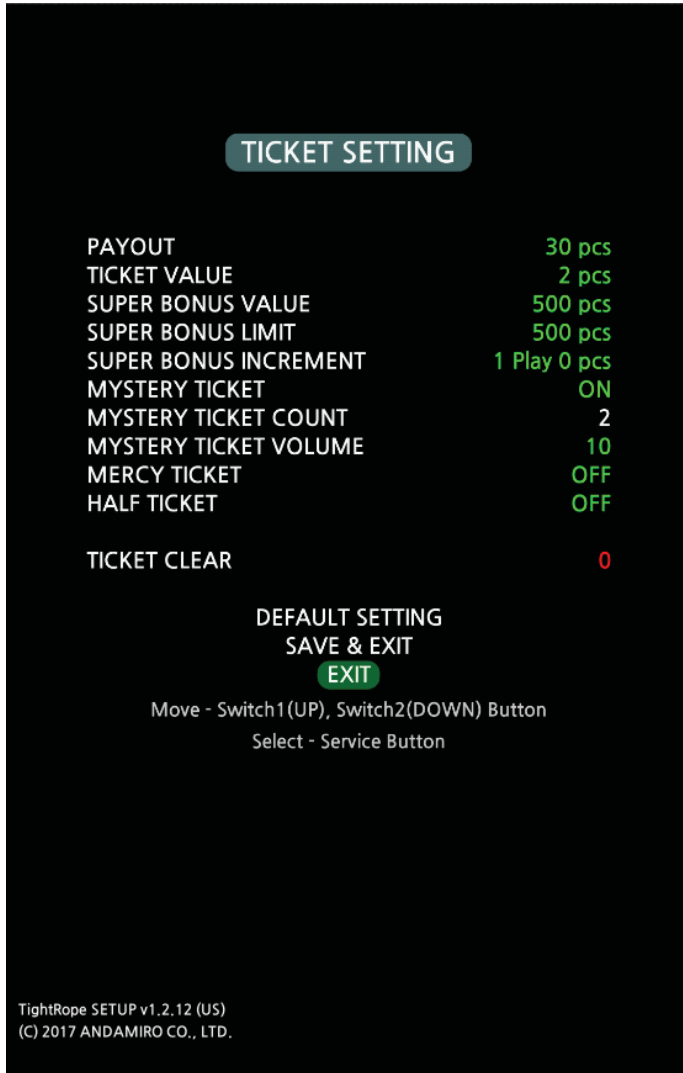

- PAYOUT : SET UP Ticket Pay out,
The range is '2-70 pcs', Ascent in 2 pcs per button input. (Fr. 70 to. 2 rotation)
Default Setting is '30 pcs'
If the setting is below 5, Super bonus increment and Mystery ticket function will be off.
And the game level will be Junior, Chaser level will be easy and Super bonus hurdle level will be easy in automatically.
- TICKET VALUE : Set ticket value on the game as 1 ticket or 2 tickets.
If you set payout "30" and ticket value "2", then there will be 15 tickets with the 2 tickets value of each in the game field.
Default is "2"
- SUPER BONUS VALUE : SET UP super bonus ticket amount
The range is '50 pcs-3000 pcs',
Ascent in 50 pcs per button input.
Default Setting is '500 pcs'
- SUPER BONUS LIMIT : SET UP super bonus limit
The range is '50 pcs-3000 pcs',
Ascent in 50 pcs per button input.
Default Setting is '500 pcs'
SUPER BONUS CANNOT BE SET UNDER SUPER BONUS VALUE ABOVE.

- SUPER BONUS INCREMENT : SET UP super bonus increment per 1 play
If the value is '0', no super bonus increment. The range is '0 pcs-50 pcs',
Ascent in 1pcs per button input.
Default Setting is '0pcs'
- MISTERY TICKET : SET UP to display the Mystery Ticket in the game.
- MISTERY TICKET COUNT : SET UP No. of the Mystery Ticket.

SEQUENCE	DESCRIPTION	NO. OF TICKETS	WHERE TO PLACE
1	1	1 pcs	150m~200m - 1 pcs
2	2	2 pcs	100m~150m - 1pcs / 150m~200m - 1 pcs
3	3	3 pcs	50m~100m - 1pcs / 100m~150m - 1pcs / 150m~200m - 1 pcs

- MISTERY TICKET VOLUME : SET UP No. of Mystery Ticket Volume.
Setting range is '6~16'. (Increased by 2)
Set value will be divided by above mystery ticket number.

SEQUENCE	DESCRIPTION	SEQUENCE	DESCRIPTION
1	6	4	12
2	8	5	14
3	10	6	16

- MERCY TICKET : SET UP No. of mercy Ticket.

SEQUENCE	DESCRIPTION	SEQUENCE	DESCRIPTION
1	1	7	7
2	2	8	8
3	3	9	9
4	4	10	10
5	5	11	OFF
6	6		

- HALF TICKET : SET UP Half Ticket.

SEQUENCE	DESCRIPTION
1	ON
2	OFF

- TICKET CLEAR : Initialize Tickets.
On the right side of the Menu, Displays the current Tickets.
- DEFAULT SETTING : Reset 'Ticket Setting' to factory setting.
- SAVE & EXIT : Save the changed setting and Enter to the 'MAIN SETUP MENU' Page.
- EXIT : Do not save the changed setting and Enter to the 'MAIN SETUP MENU' Page.

[CEC Direction Settings]

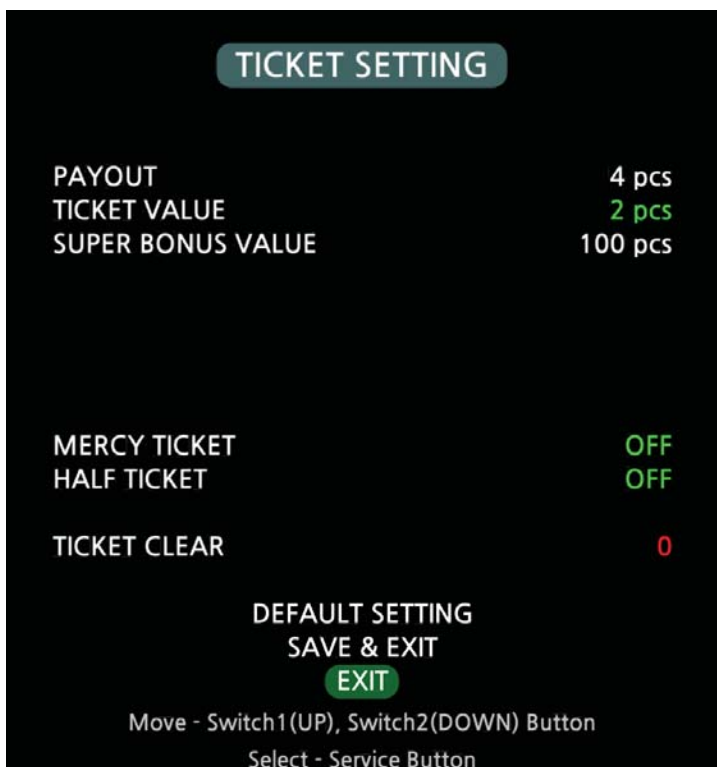

4-1-5. SOUND SETTING

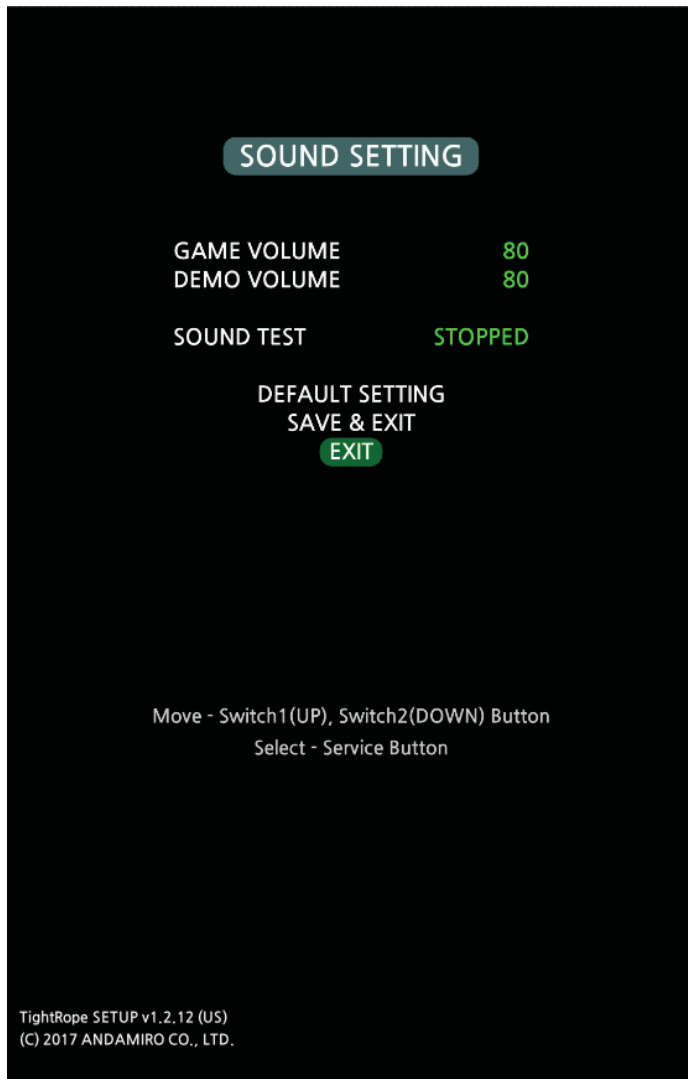

- GAME VOLUME : SET UP Game volume.

- DEMO VOLUME : SET UP Demo volume.

SEQUENCE	VOLUME	SEQUENCE	VOLUME
1	0	17	80
2	5	18	85
3	10	19	90
4	15	20	95
~	~	21	100

- SOUND TEST : Play a sound source for the Test Speaker.

DESCRIPTION	FEEDBACK
STOP	Do not playing the test sound source
PLAY	Playing the test sound source

- DEFAULT SETTING : Reset 'Sound Setting' to factory setting.

- SAVE & EXIT : Save the changed setting and Enter to the 'MAIN SETUP MENU' Page.

- EXIT : Do not save the changed setting and Enter to the 'MAIN SETUP MENU' Page.

4-1-6. BOOKKEEPING

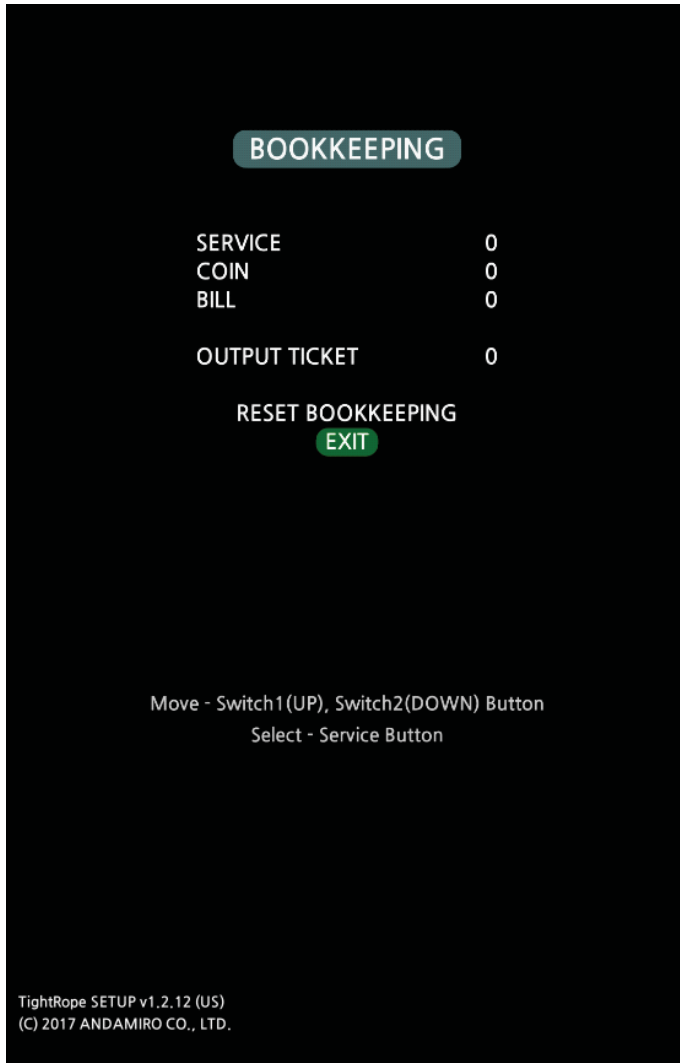

- SERVICE : Displays Credit count by pushing Service Button.
- COIN : Displays Credit count by coin counter.
- BILL : Displays Credit count by bill counter.
- OUTPUT TICKET : Displays dispensed Tickets.
- RESET BOOKKEEPING : Reset 'Bookkeeping' setting.
- EXIT : Back to the 'MAIN SETUP MENU' Page.

4-1-7. STATISTICS

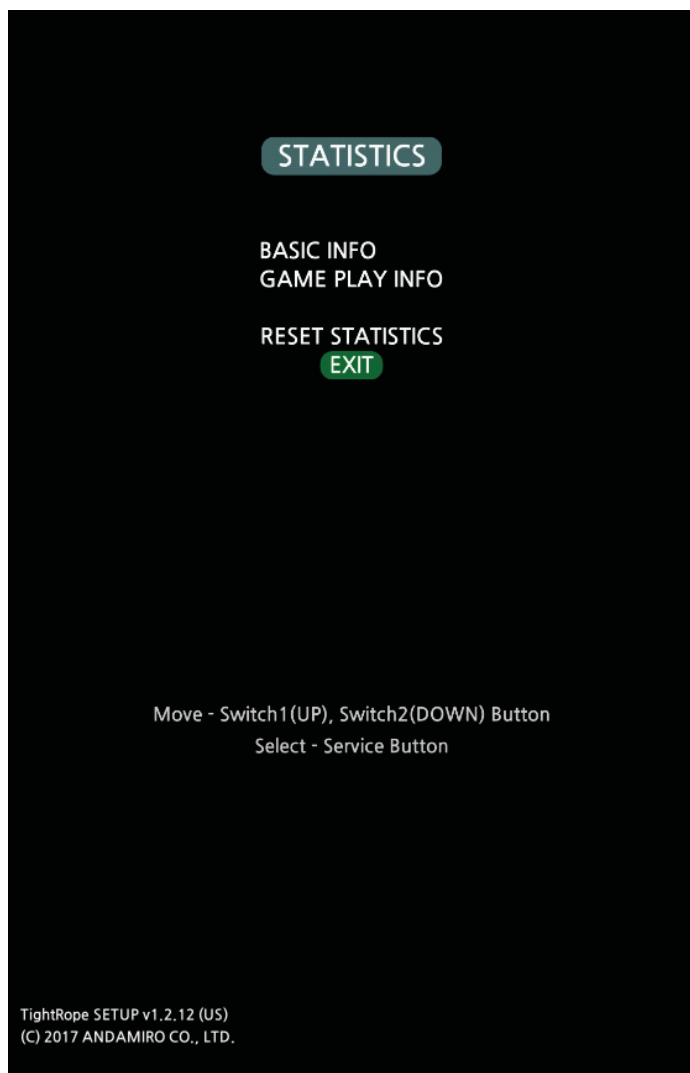

- BASIC INFO : Displays Basic Information page.
- GAME PLAY INFO : Displays Game Play Information page.
- RESET STATISTICS : Reset the Statistics data.
- EXIT : Back to the 'MAIN SETUP MENU' Page.

[BASIC INFO]



- TOTAL ACTIVE TIME : Displays total accumulated active play time since turning on to turning off the machine. (-> Displays total accumulated program operation time).
- TOTAL PLAY TIME : Displays total accumulated play time from first pushing start button to last 'GAME OVER' page.
- AVERAGE PLAY TIME : Displays average play time of main game.
- MAX PLAY TIME : Displays the longest play time of main game.
- MIN PLAY TIME : Displays the shortest play time of main game.
- EXIT : Exit the 'Basic Info' page and Enter to the 'Statistics' Page.

[GAME PLAY INFO]

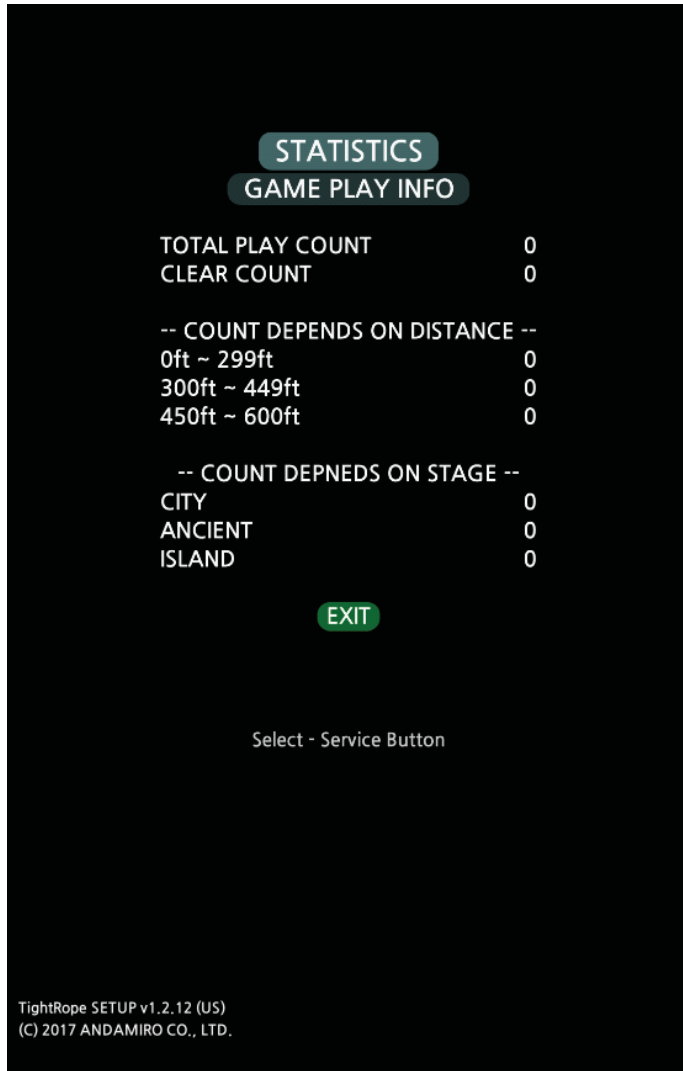

- TOTAL PLAY COUNT : Displays total accumulated played count.
- CLEAR COUNT : Displays total count of cleared stage.
- COUNT DEPENDS ON DISTANCE :
Displays distance when failed according to following ranges.
"0ft ~ 299ft" / "300ft ~ 449ft"
/ "450ft ~ 600ft"
- COUNT DEPENDS ON STAGE : Displays the stage that selected by player.
"City" / "Ancient" / "Island"
- EXIT : Exit the 'Basic Info' page and Enter to the 'Statistics' Page.

4-1-8. SYSTEM UPDATE

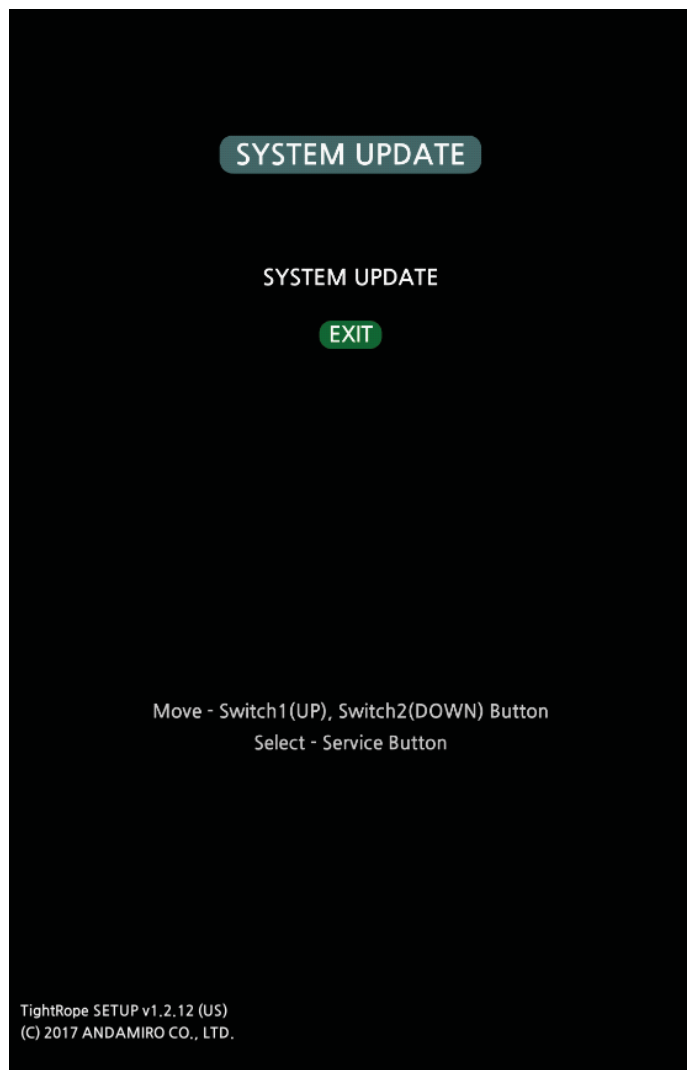

- SYSTEM UPDATE : Enter to the 'System Update' page.

- EXIT : EXIT the 'System Update' page.
Then, Enter to the MAIN Page.

[SYSTEM UPDATE]

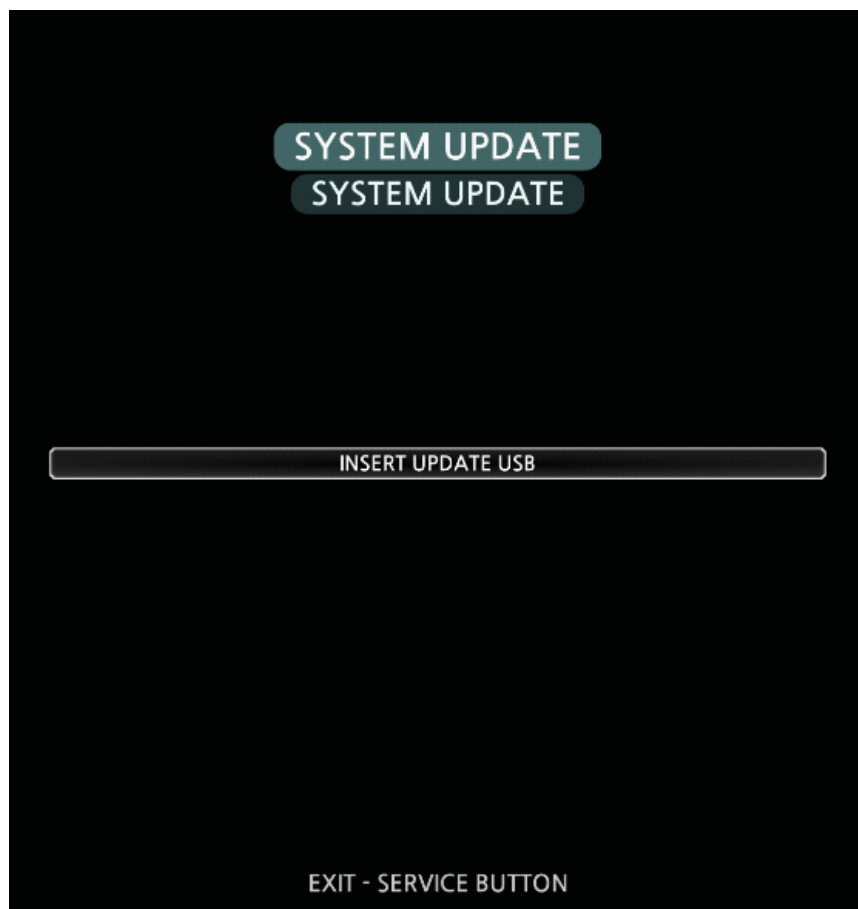

	CASE	DISPLAY
Update Stand By	Description to system updates	Insert the USB containing the update files.
Update File Check	Notify checking system update files in the USB	Checking update files
	Error Message - no USB recognition	No USB drive found.
	Error Message - In case of the current operating system version and the update version is same version.	The file that has already been updated or previous versions of the update file.
	Error Message - In case of the update files does not exist on the specified path in the USB.	No update file found.
Update File Copy	Error Message - In case of some update files are missing from the USB or problem has occurred.	Cannot copy update files - Update file was missing or problem has occurred.
	Copying system update files from USB to HDD	Copying update files ({No. of current files} / {No. of total files})
Ready for Update	Error Message - In case of the problem has occurred during Recognizing USB / In case of the problem has occurred during copying	Problem has occurred during copying Update Files.
	Notify that system updates was ready.	Ready for update. Reboot the system. (Counting)

4-1-9. FACTORY SETTING

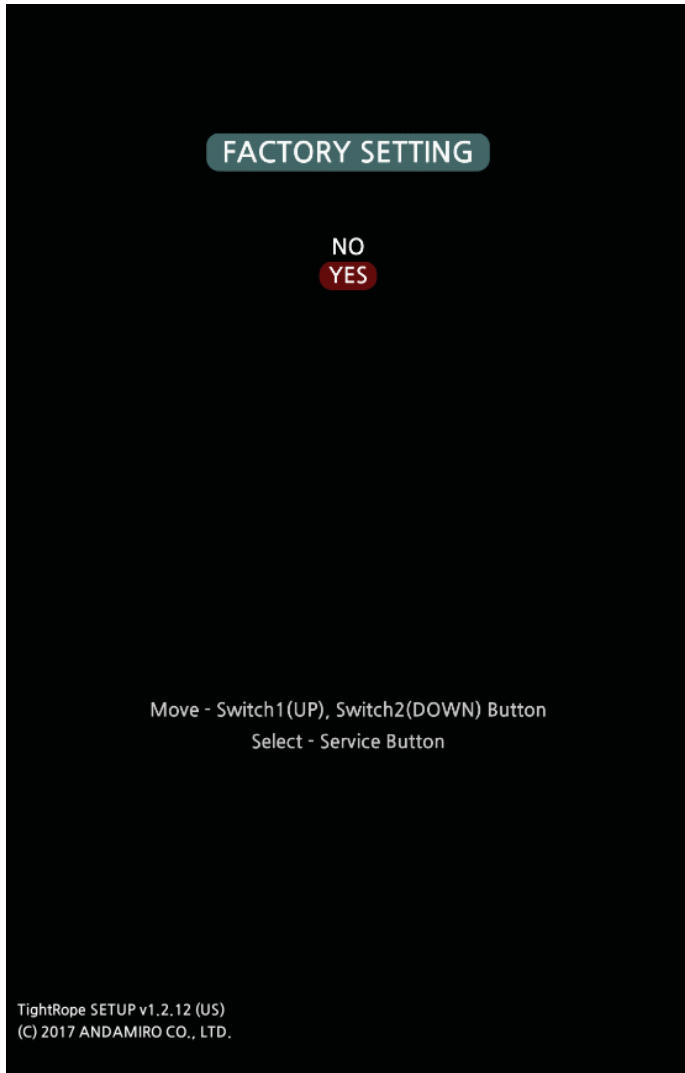

- NO : Do not 'Factory Setting' and Enter to the previous Page.
- YES : 'Factory Setting' and Enter to the previous Page.

4-2. ERROR CODE

ERROR CODE	ERROR	DESCRIPTION and CHECK POINT	LIMITATIONS
E0-02	SYSTEM	SETUP DATA READ / WRITE ERROR 1. SETUP MENU -> FACTORY DEFAULT -> SYTEM REBOOT 2. REPLACE HDD IF STILL SAME PROBLEM	- No coin input - No start button input - No wheel encoder input - No game play
E0-03		SETUP DATA ERROR 1. SETUP MENU -> FACTORY DEFAULT -> SYSTEM REBOOT 2. REPLACE HDD IF STILL SAME PROBLEM	- No coin input - No start button input - No wheel encoder input - No game play
E0-10		I/O BOARD CONNECTION ERROR 1. CHECK USB CONNECTION BETWEEN MAIN BOX AND I/O BOARD 2. REPLACE I/O BOARD OR MAIN BOX IF STILL SAME PROBLEM	- Whole I/O are not working - No game play
E0-20		USB LOCK DEVICE CONNECTION ERROR 1. CHECK CONNECTION BETWEEN MAIN BOX AND USB LOCK 2. CHECK RED LED LIGHT IS ON AT USB LOCK 3. REPLACE USB LOCK OR MAIN BOX IF STILL SAME PROBLEM	- No coin input - No start button input - No wheel encoder input - No game play
E1-01	COIN SELECTOR	COIN SELECTOR SENSOR ERROR 1. CHECK NC, NO SWITCH ON COIN SELECTOR (IF IT IS ON NC, CHANGE TO NO AND REBOOT) 2. CHECK SENSOR OF COIN MACHINE	- No coin input - No start button input - No wheel encoder input - No game play
E3-01	WHEEL ENCODER	WHEEL ENCODER SENSOR ERROR 1. CHECK AND REPLACE FRONT, REAR SENSOR OF WHEEL ENCODER (SETUP MENU -> I/O TEST -> INPUT TEST -> WHEEL ENCODER TEST)	- No coin input - No start button input - No wheel encoder input - No game play
ET-01	TICKET ERROR	TICKET DISPENSING ERROR 1. CHECK TICKET JAM OR STOCK OF TICKET MACHINE 2. CHECK SENSOR, MOTOR OF TICKET DISPENSER. 3. REPLACE TICKET DISPENSER IF STILL SAME PROBLEM	- No ticket dispending - No game play

5. TROUBLESHOOTING

* General check up : Check the supply voltage and wiring connection properly
 * "NO" : Means faulty of the check up result.

5-1. MONITOR ERROR

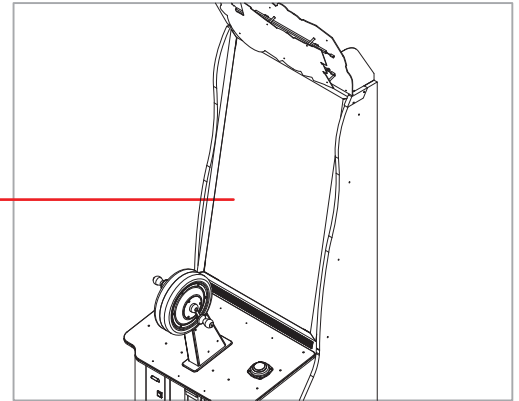

MONITOR

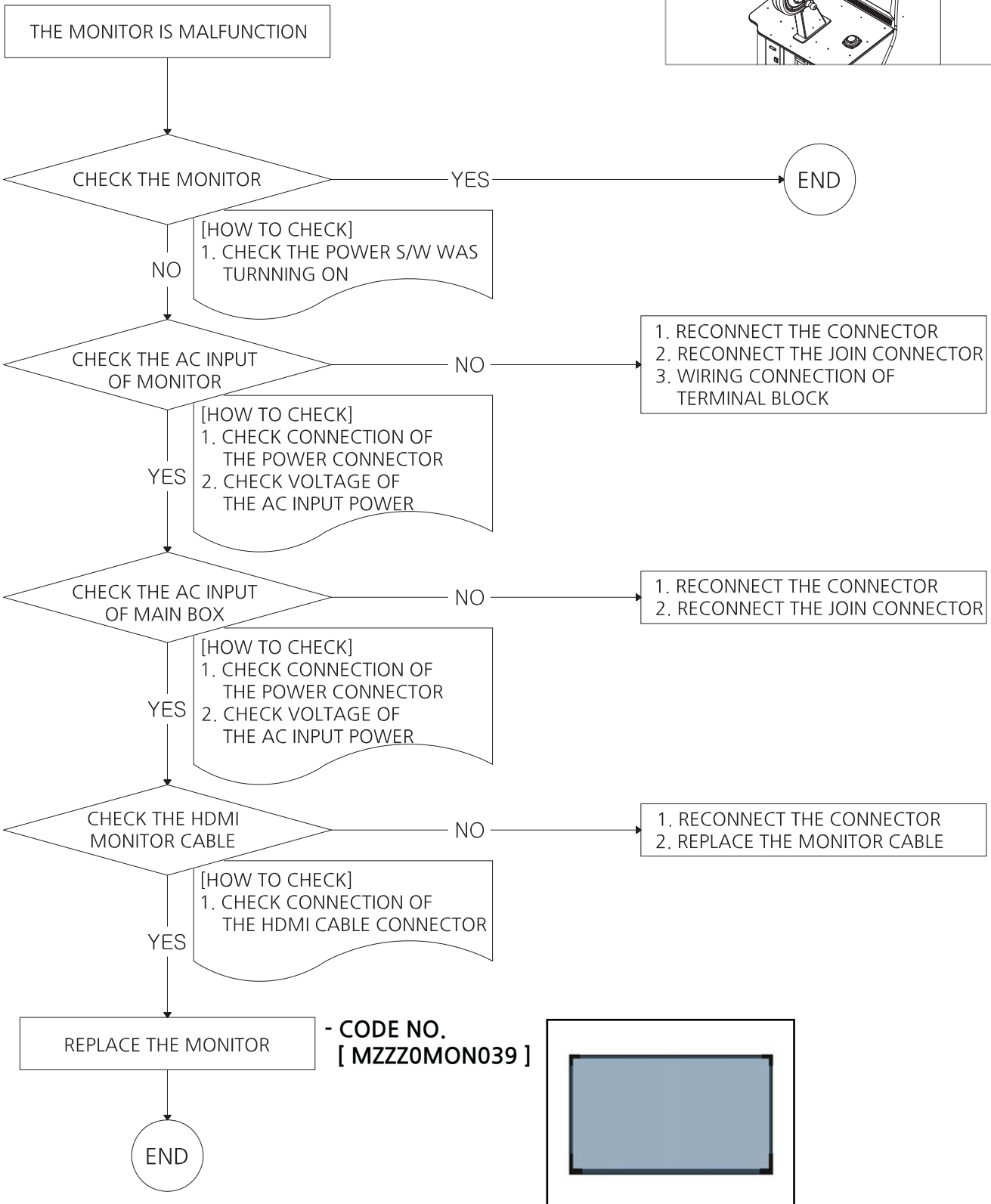

* General check up : Check the supply voltage and wiring connection properly
 * "NO" : Means faulty of the check up result.

5-2. GAME BUTTON LED PCB ERROR

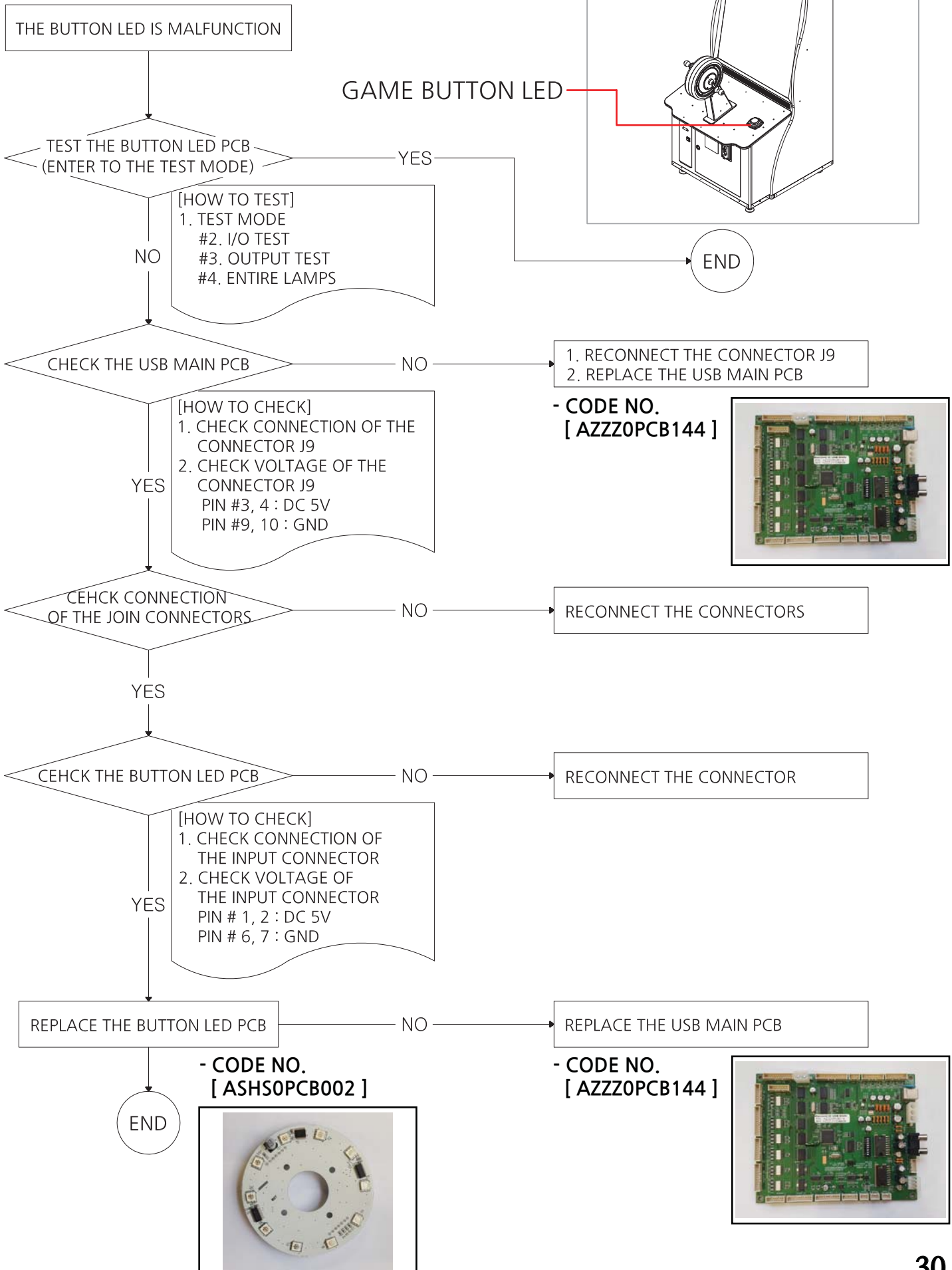

- * General check up : Check the supply voltage and wiring connection properly
- * "NO" : Means faulty of the check up result.

5-3. THE LED IS MALFUNCTION FROM CONTROLLER SIDE LED PCB

CONTROLLER SIDE LED

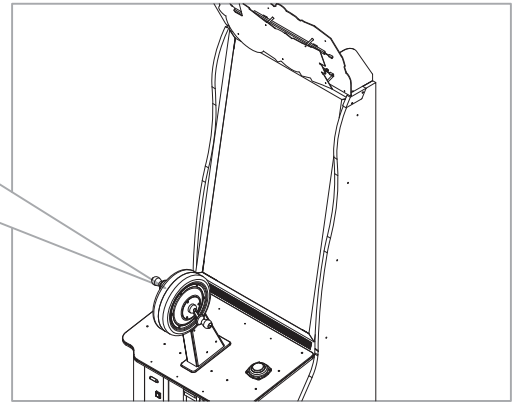
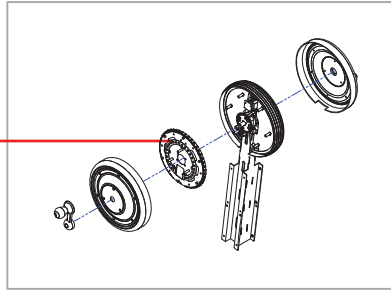

THE LED IS MALFUNCTION FROM THE CONTROLLER SIDE LED PCB
ARRANGEMENT : CONTROLLER SIDE LED PLCB-L -> WS2813 FLEX LED

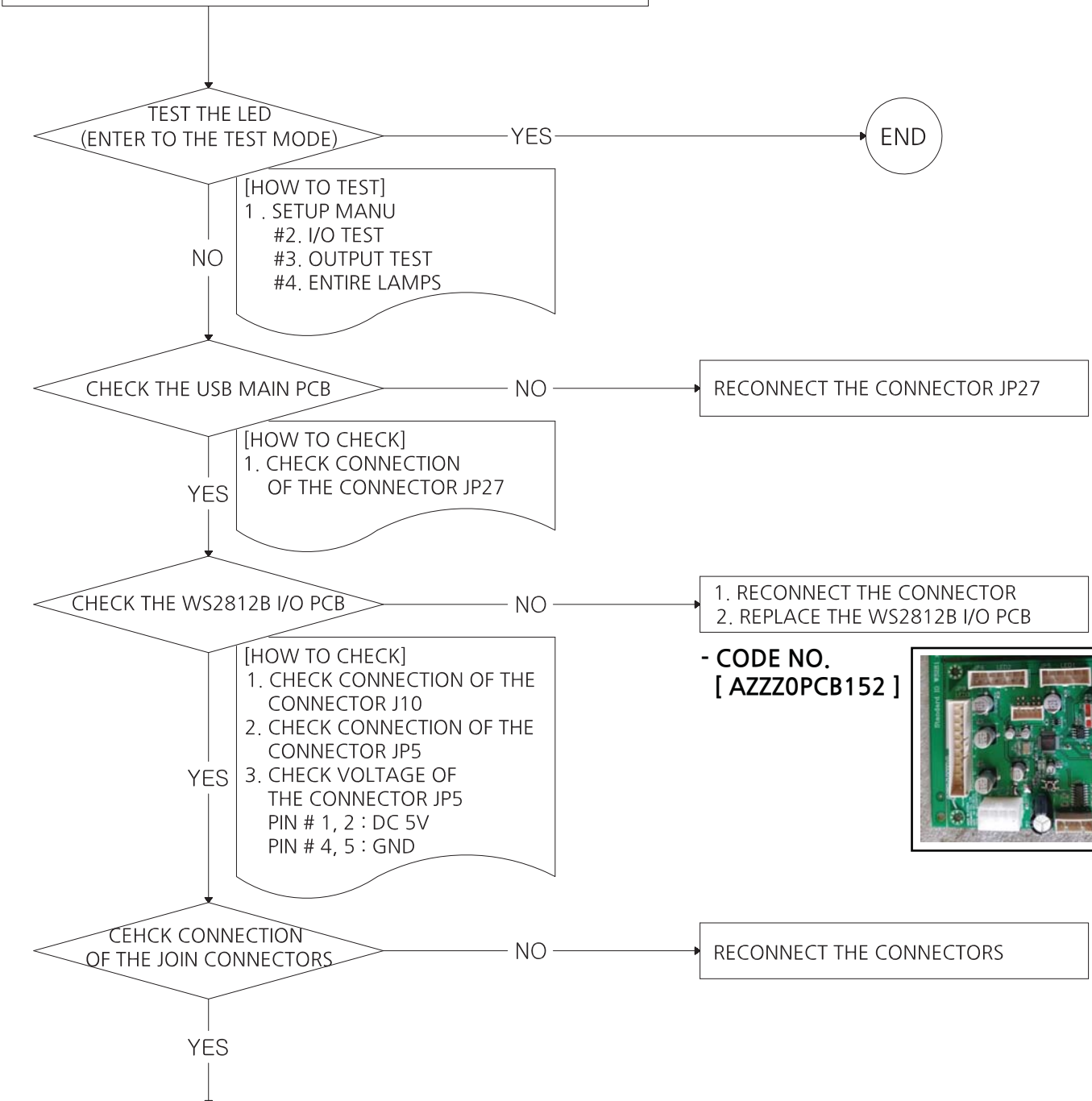

- CODE NO.
[AZZZ0PCB152]



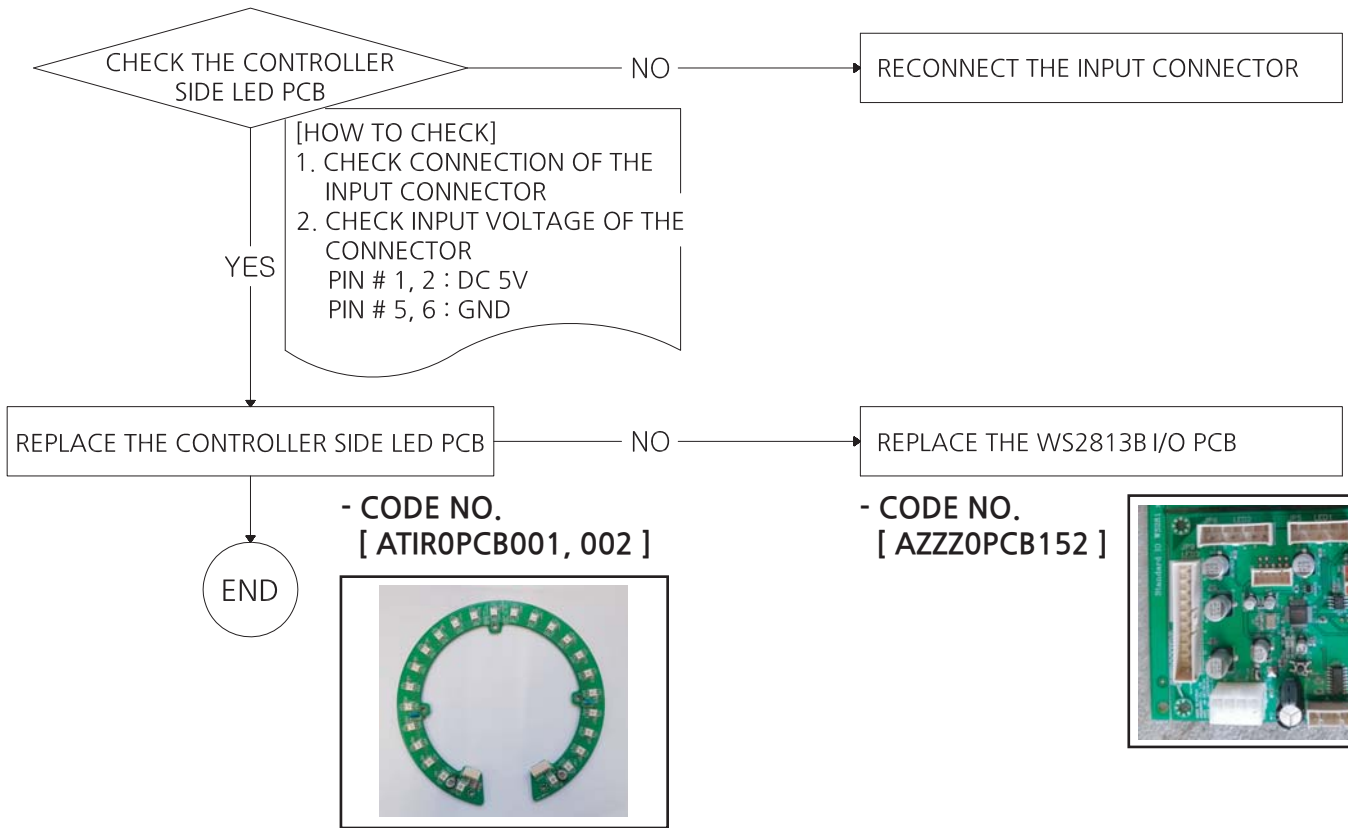

* General check up : Check the supply voltage and wiring connection properly
 * "NO" : Means faulty of the check up result.

5-4. WS2813B FLEX LED ERROR

WS2813B FLEX LED

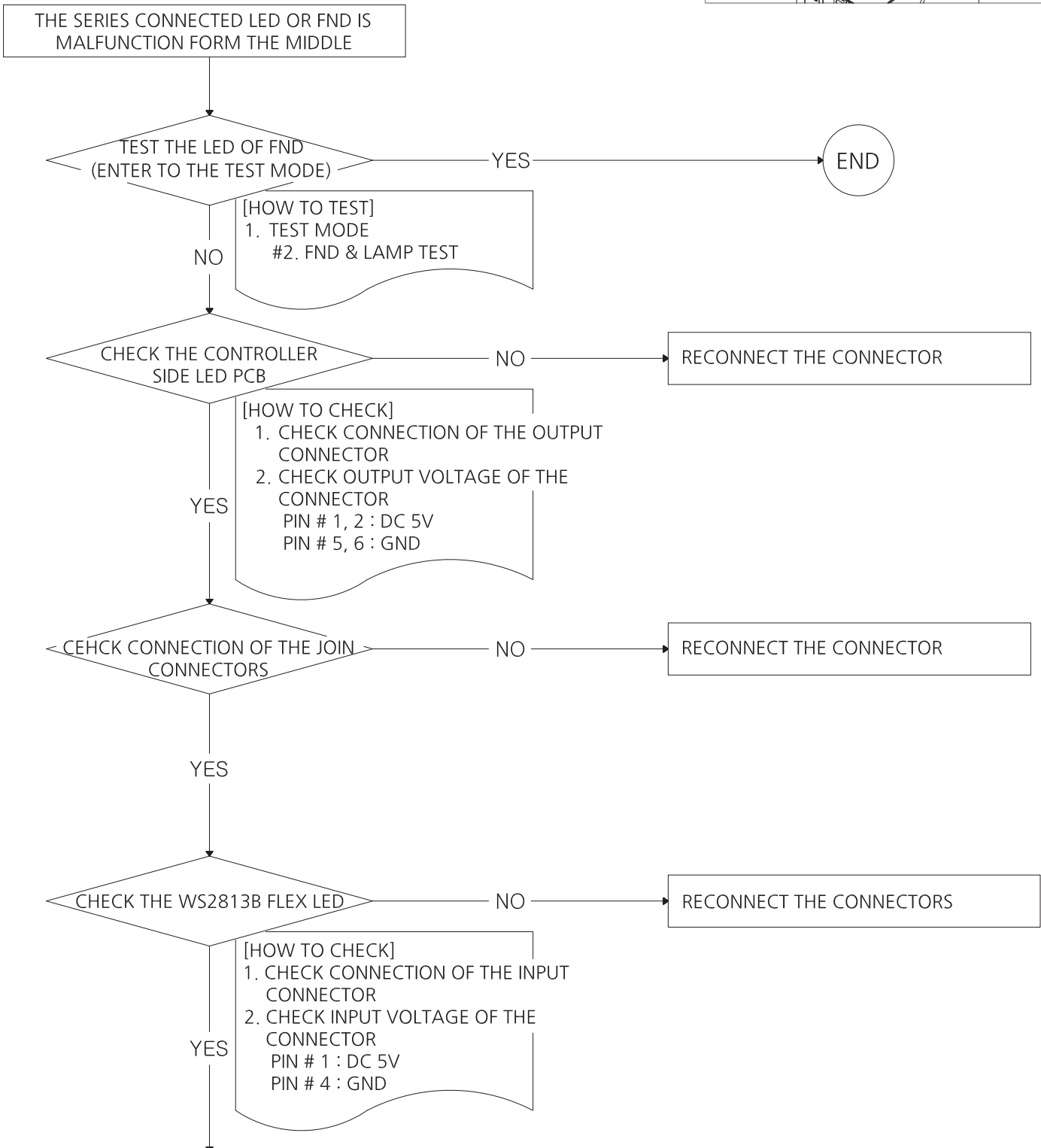
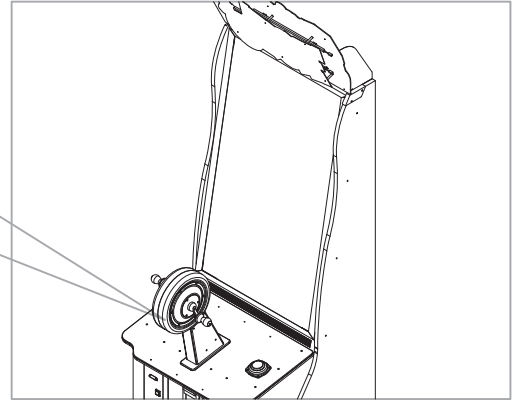
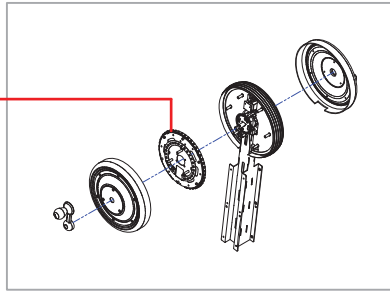

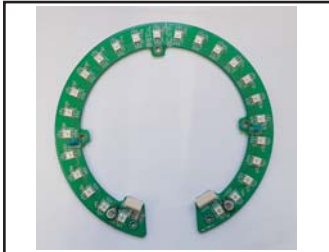
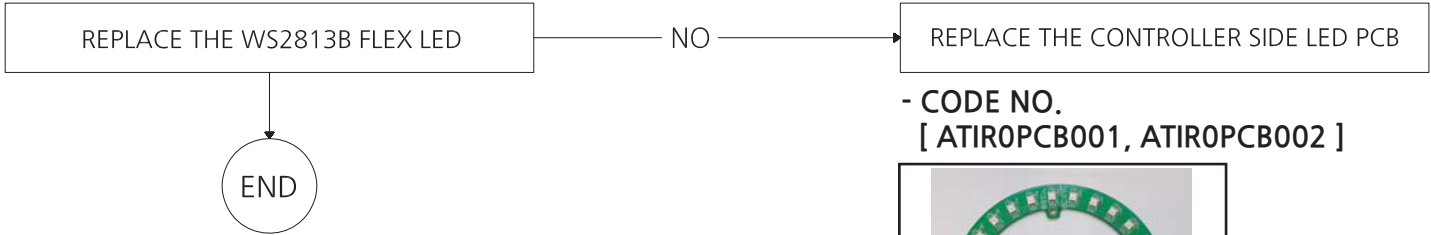

* General check up : Check the supply voltage and wiring connection properly
 * "NO" : Means faulty of the check up result.

5-5. FRONT, REAR ENCODER ERROR [E3-01]

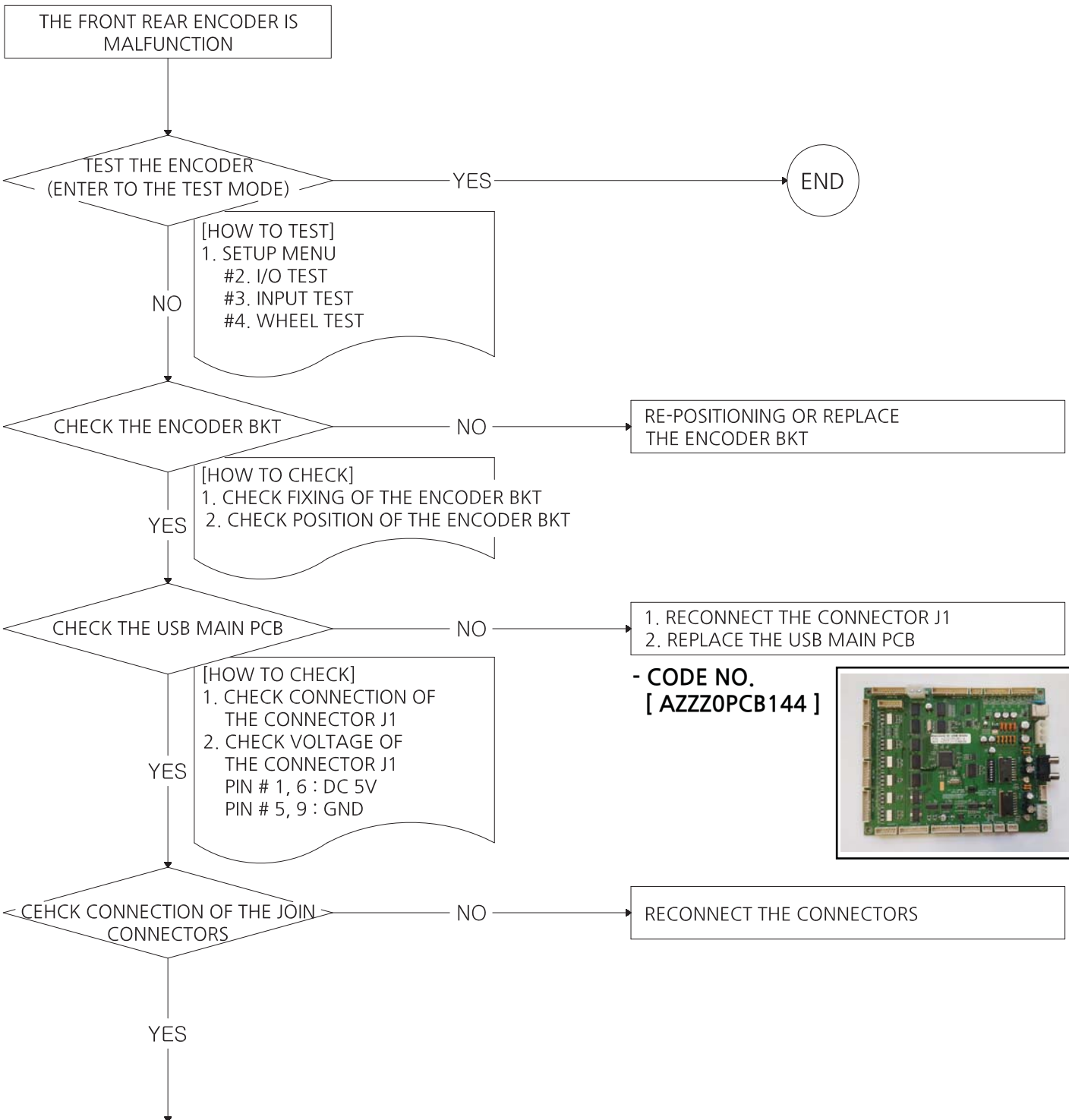
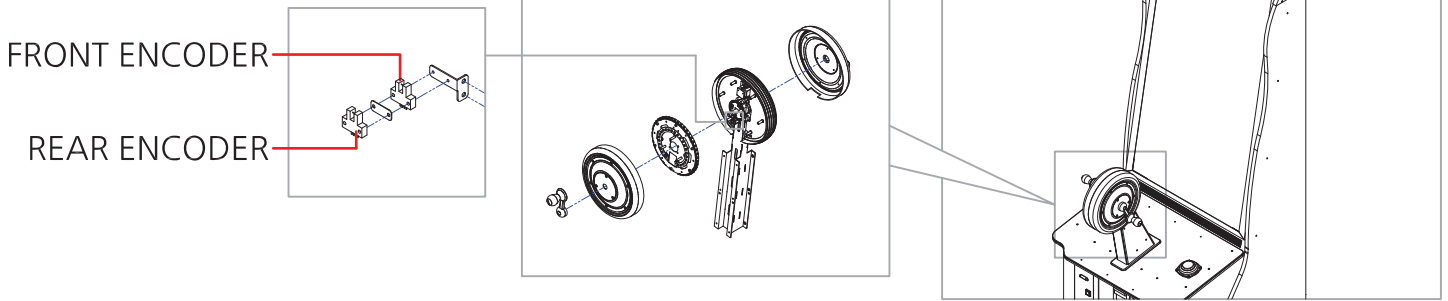

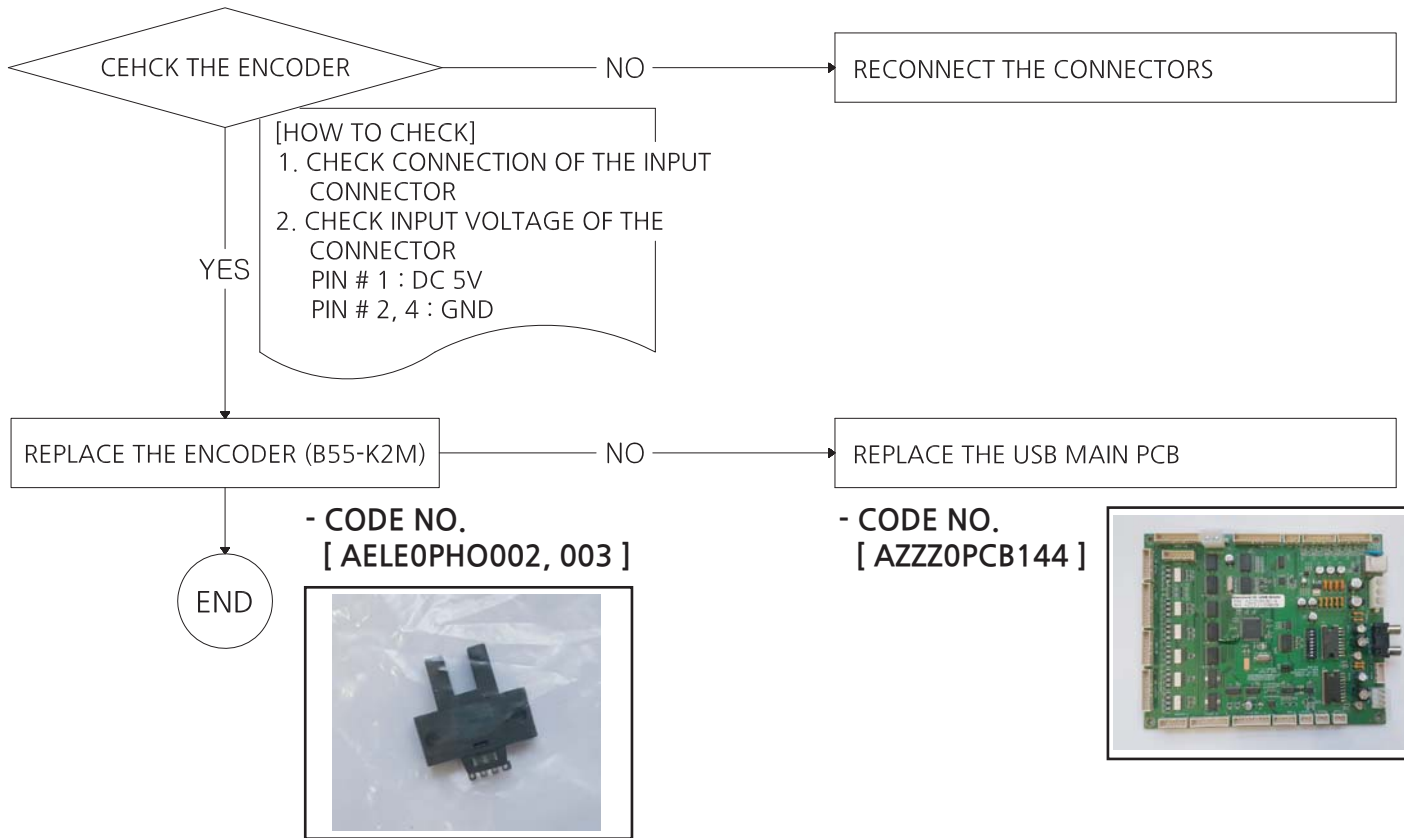

* General check up : Check the supply voltage and wiring connection properly
 * "NO" : Means faulty of the check up result.

5-6. VIBRATOR MOTOR ERROR

VIBRATOR MOTOR

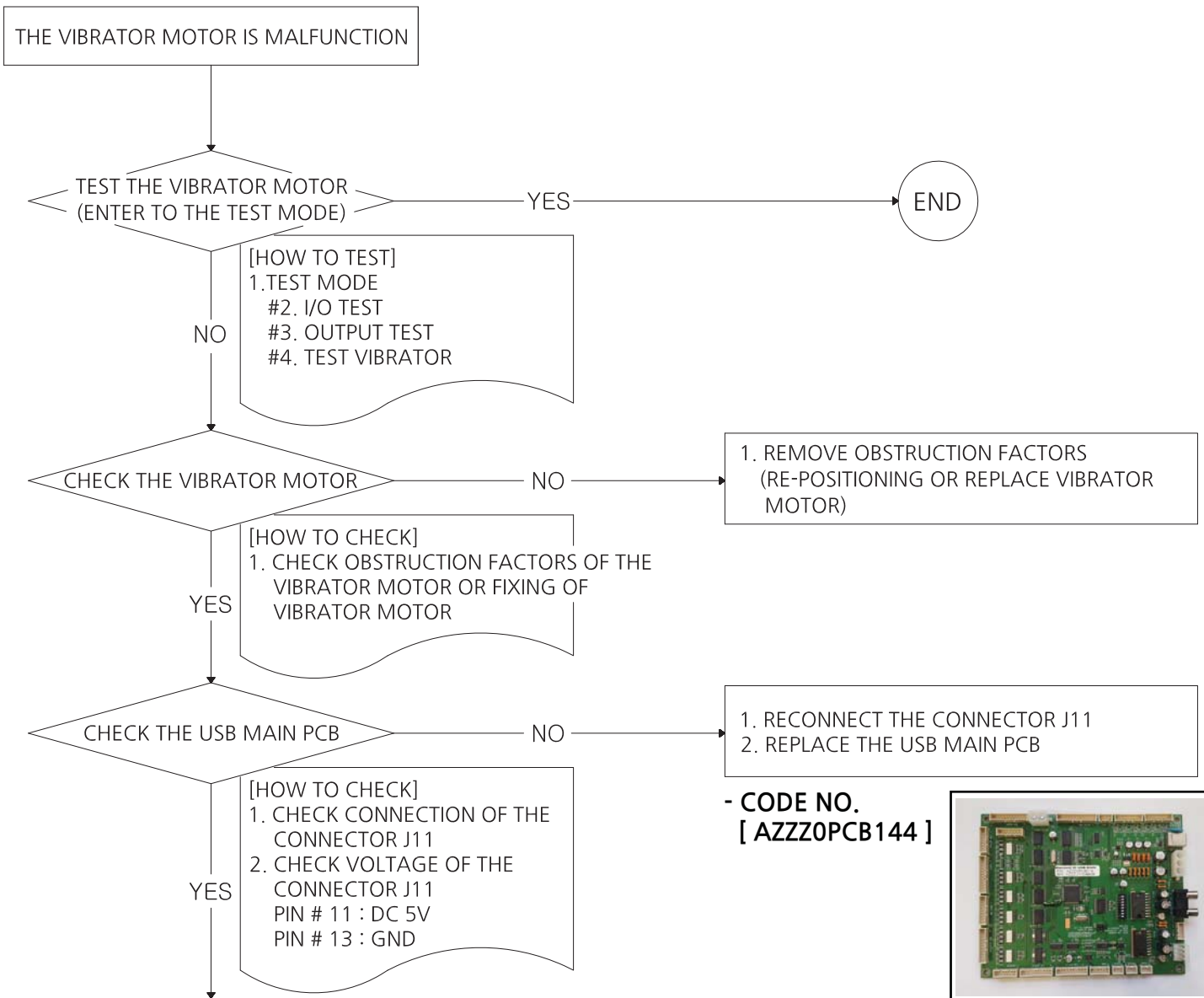
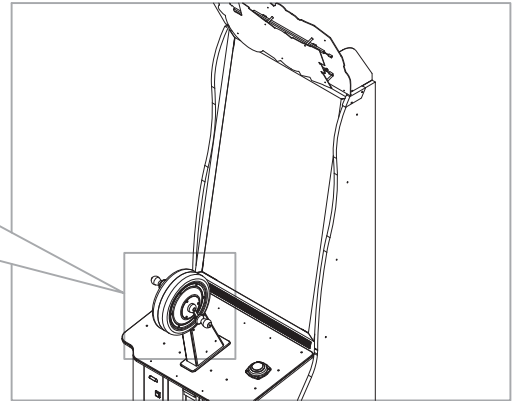
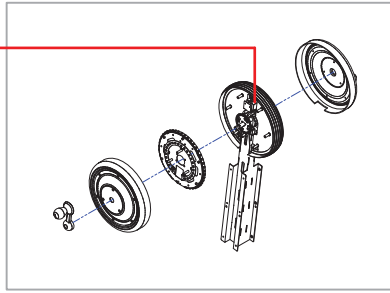

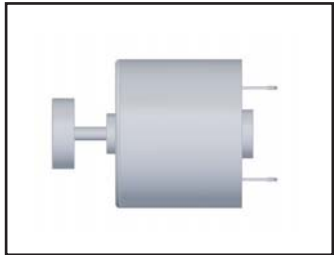
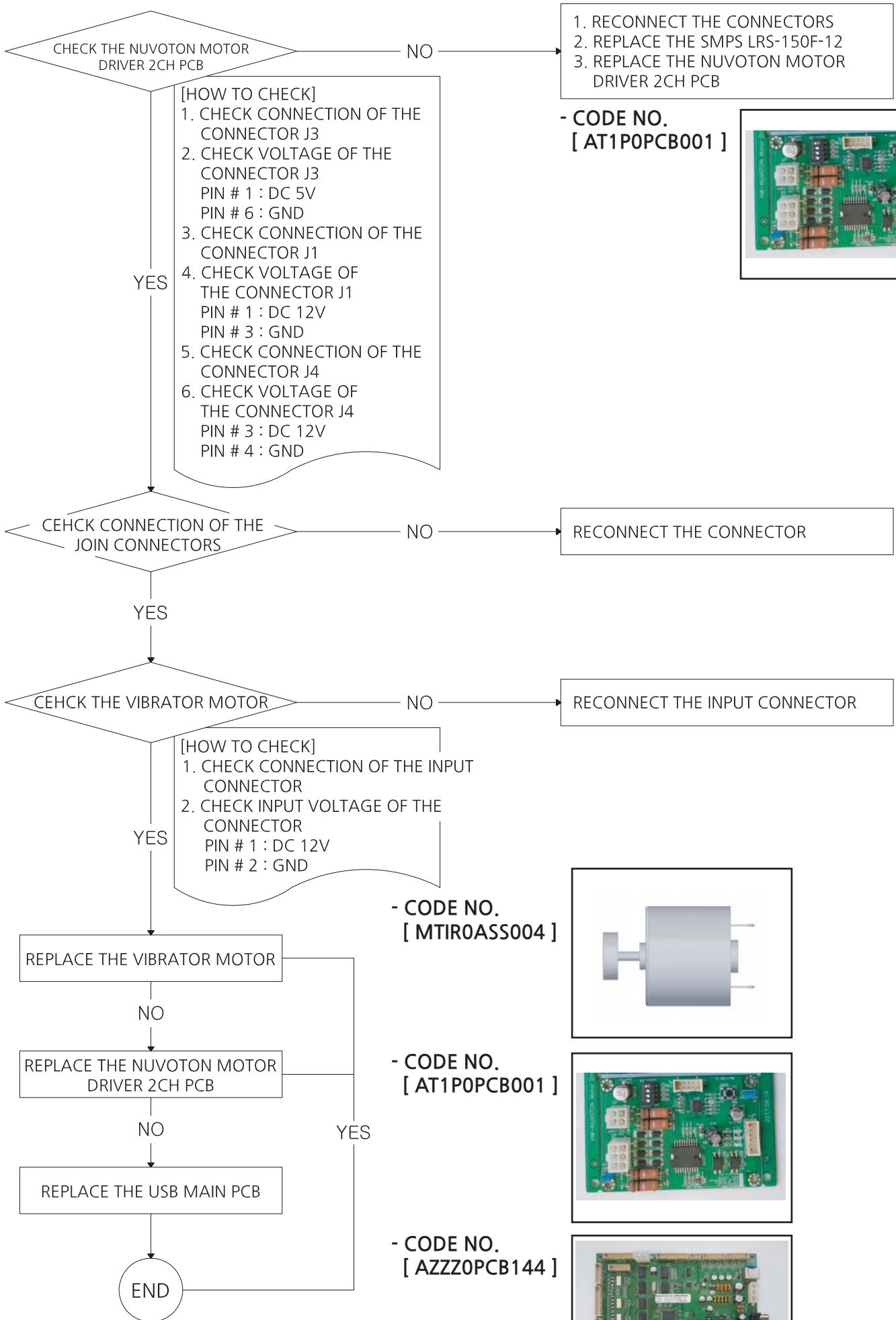

* General check up : Check the supply voltage and wiring connection properly
 * "NO" : Means faulty of the check up result.

5-7. COIN SELECTOR ERROR [E1-01]

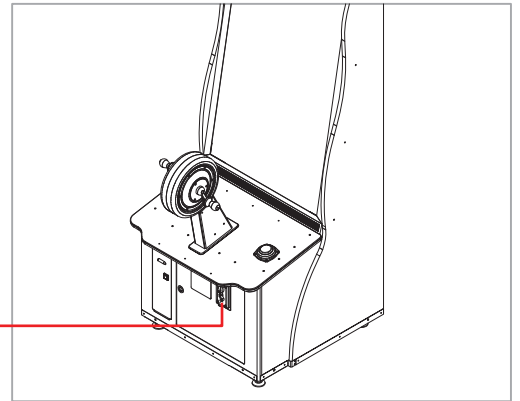

COIN SELECTOR

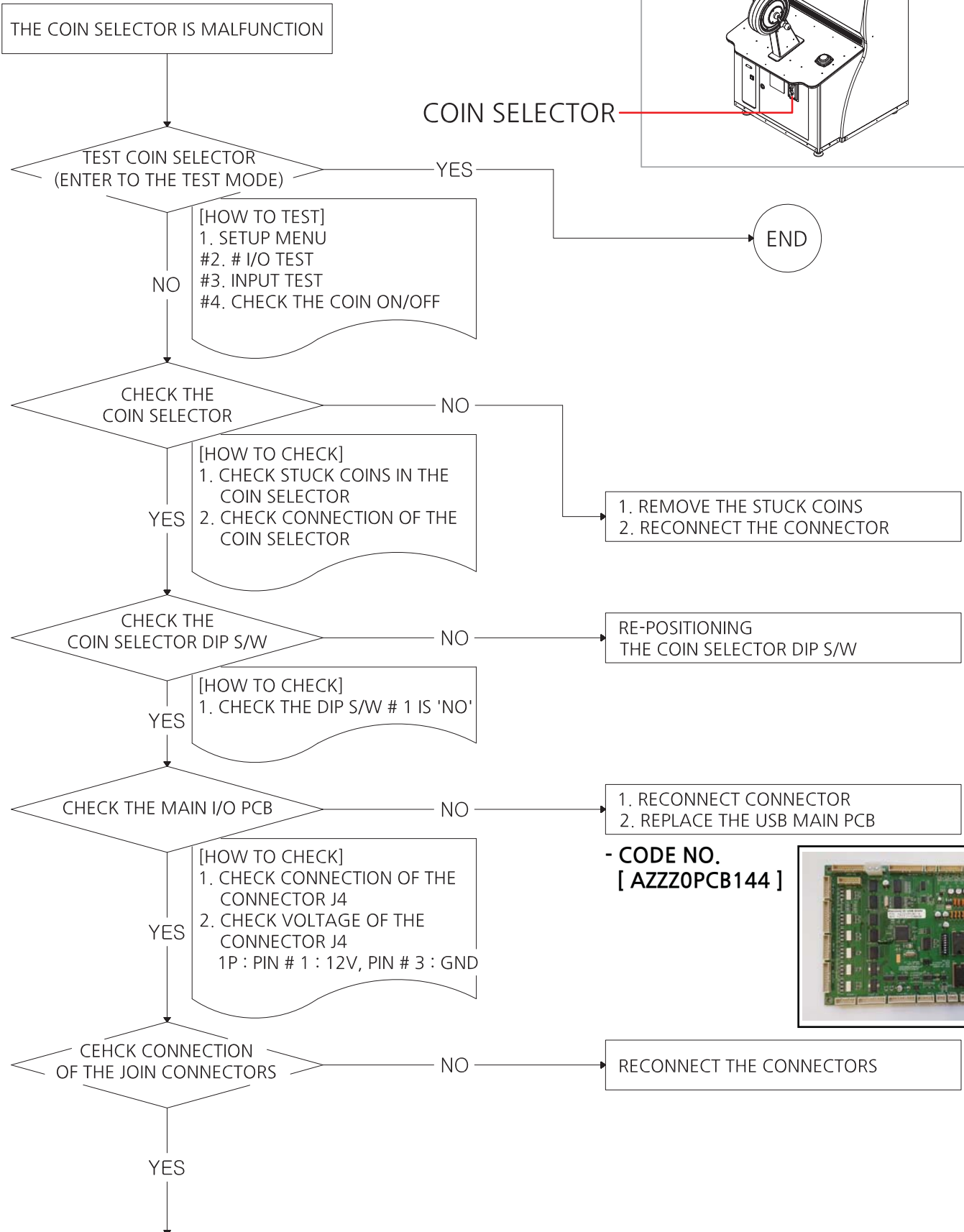

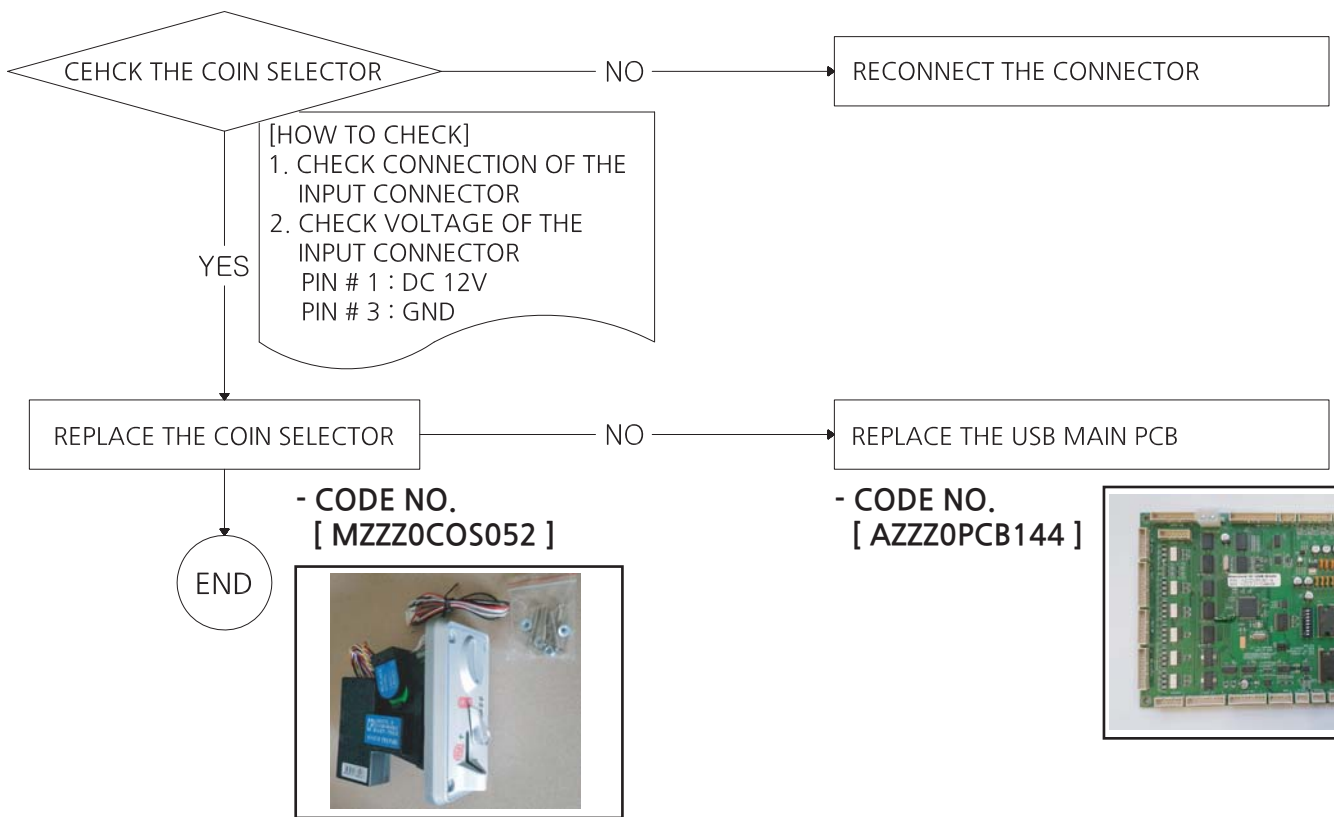

* General check up : Check the supply voltage and wiring connection properly
 * "NO" : Means faulty of the check up result.

5-8. TICKET DISPENSER ERROR [ET-01]

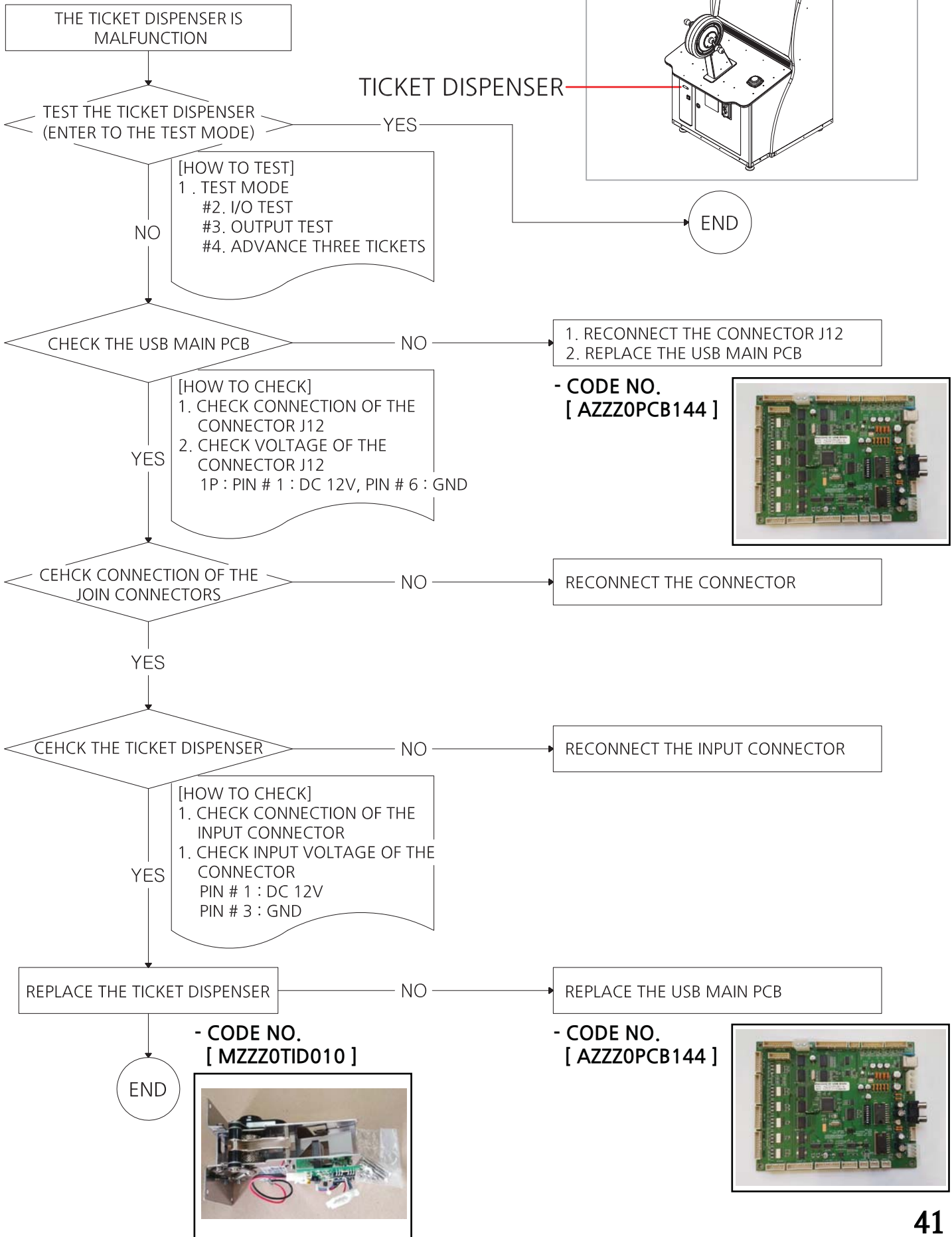

* General check up : Check the supply voltage and wiring connection properly
 * "NO" : Means faulty of the check up result.

5-9. COUNTER ERROR

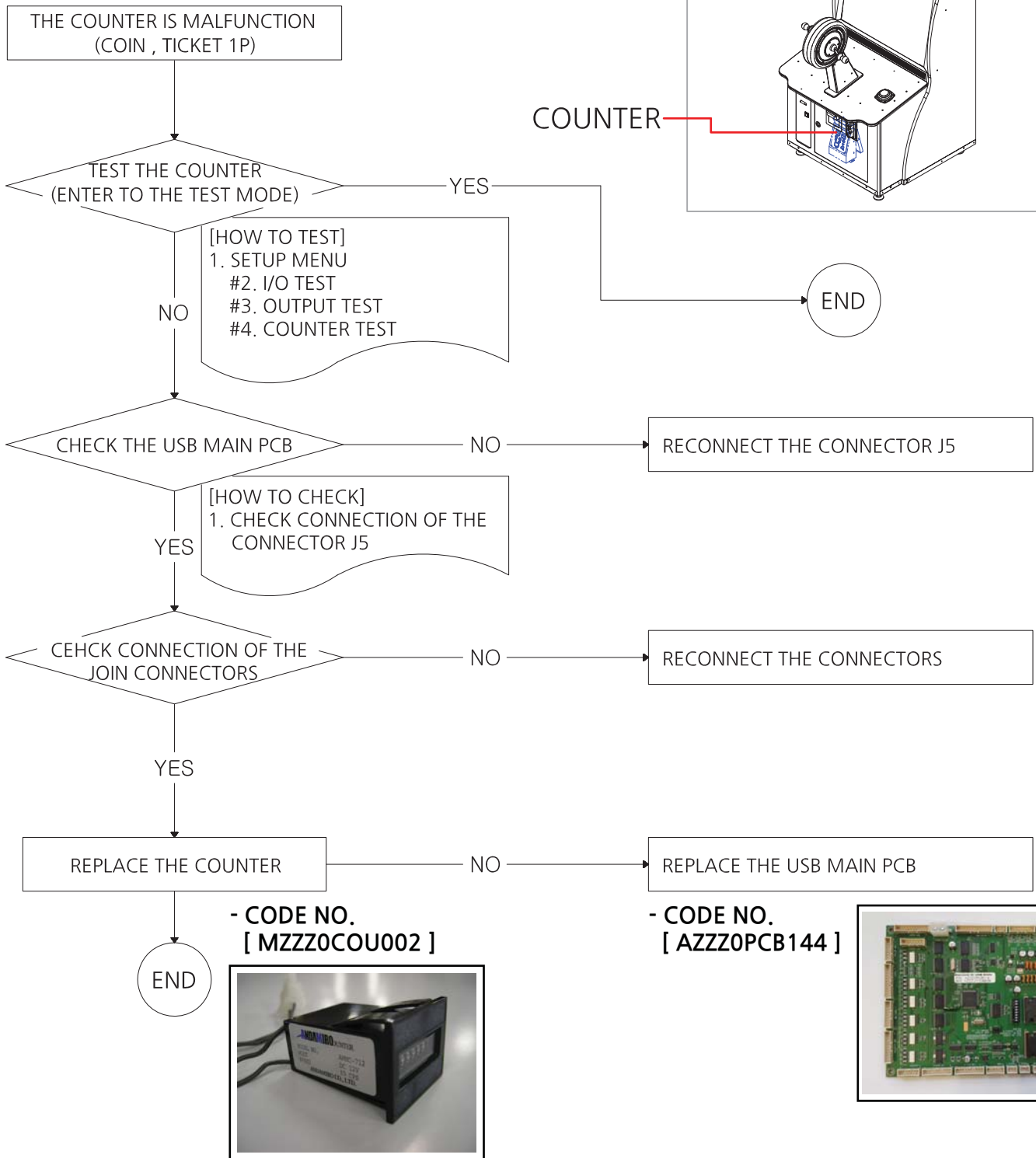

- * General check up : Check the supply voltage and wiring connection properly
- * "NO" : Means faulty of the check up result.

5-10. SETUP BUTTON ERROR

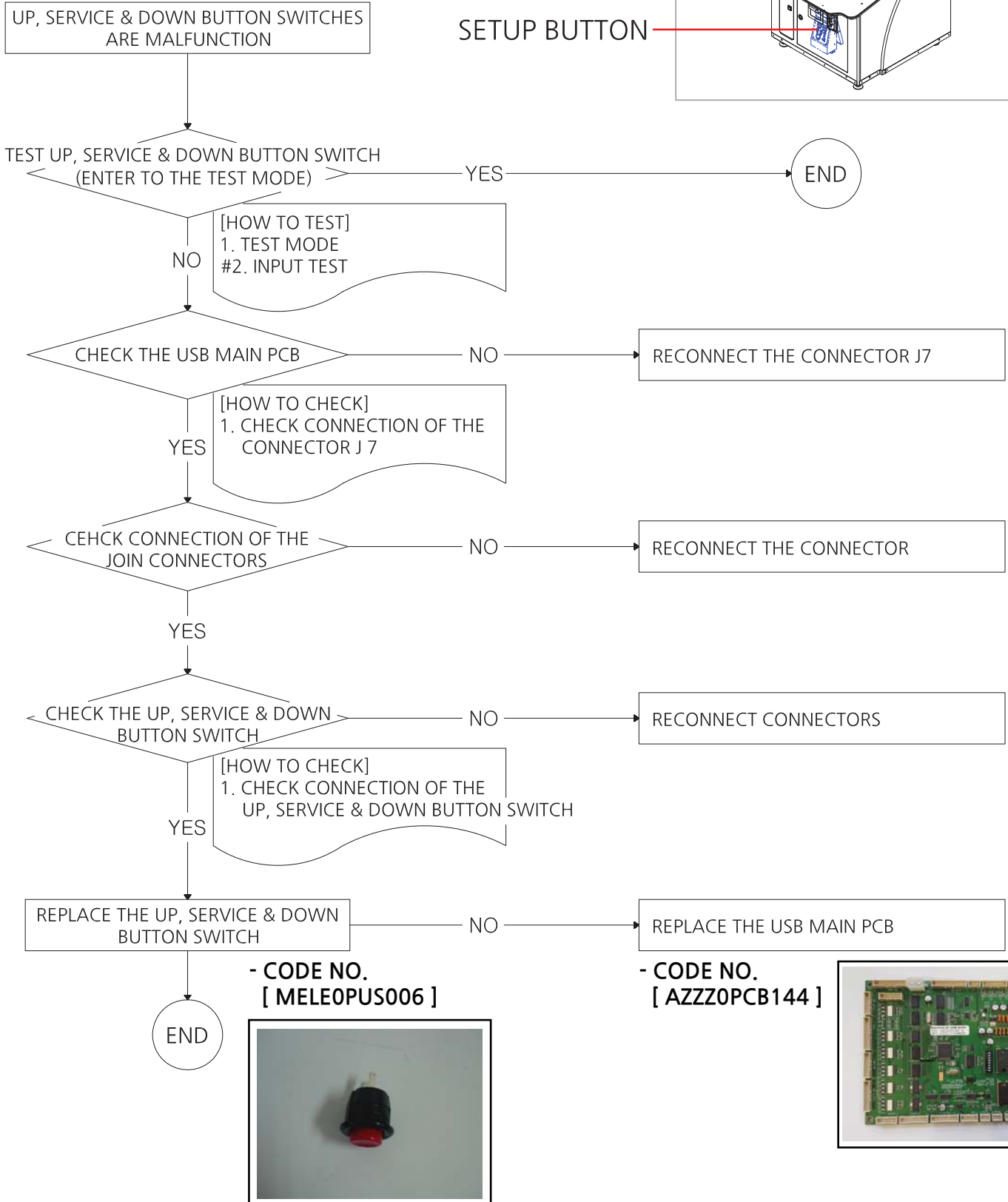
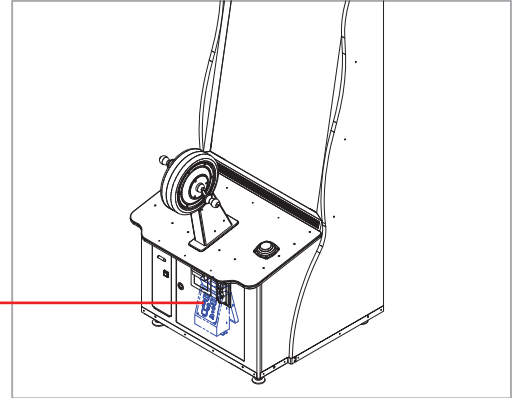

* General check up : Check the supply voltage and wiring connection properly
 * "NO" : Means faulty of the check up result.

5-11. SOUND ERROR

SOUND

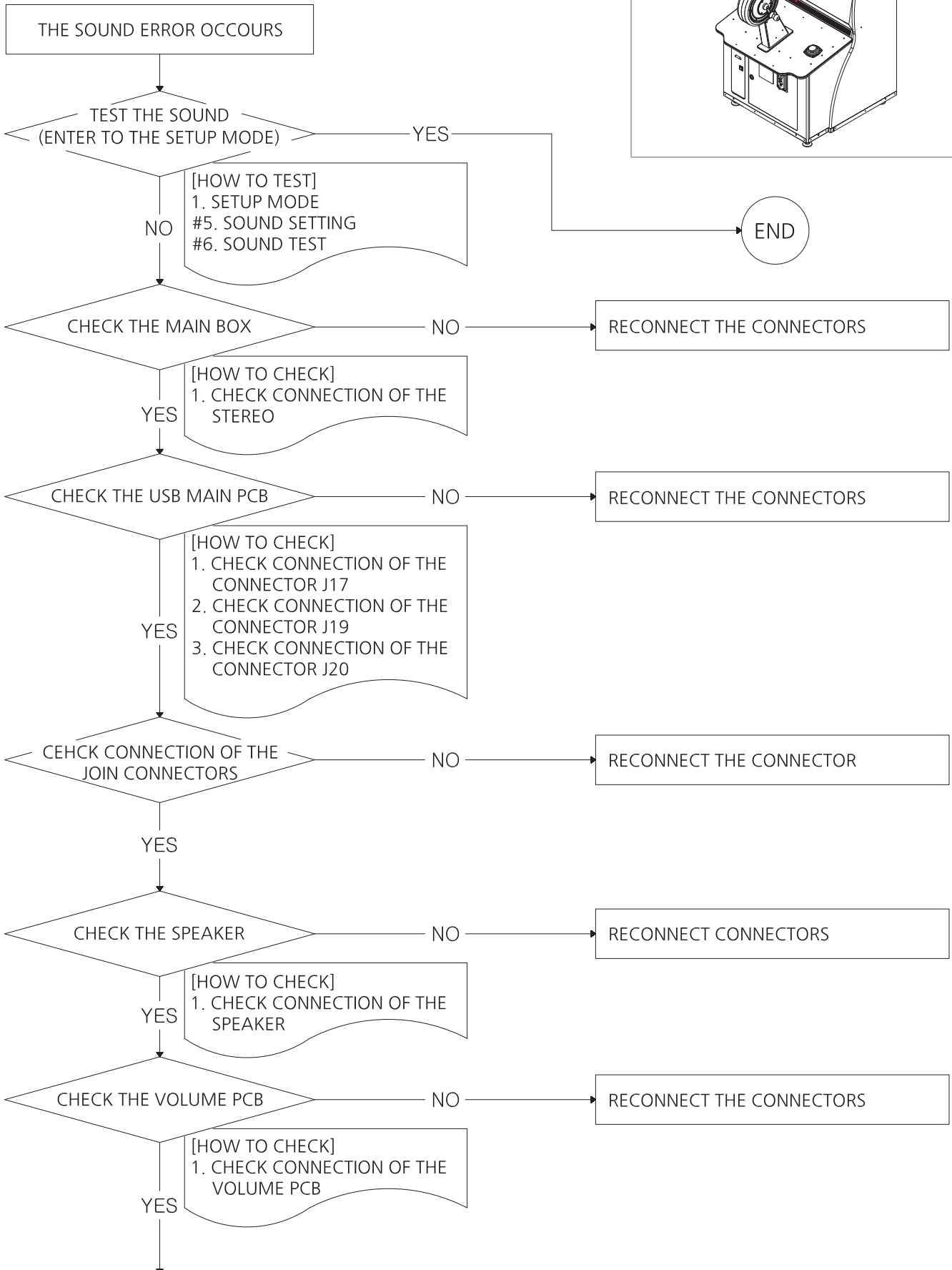
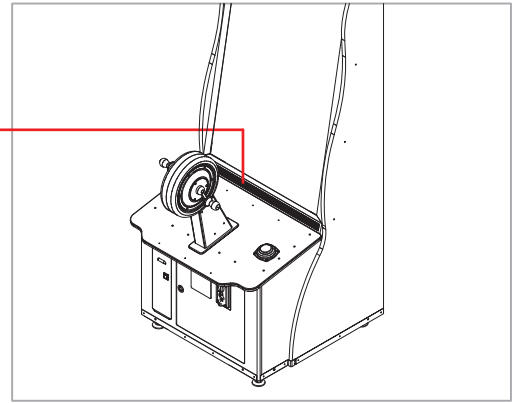

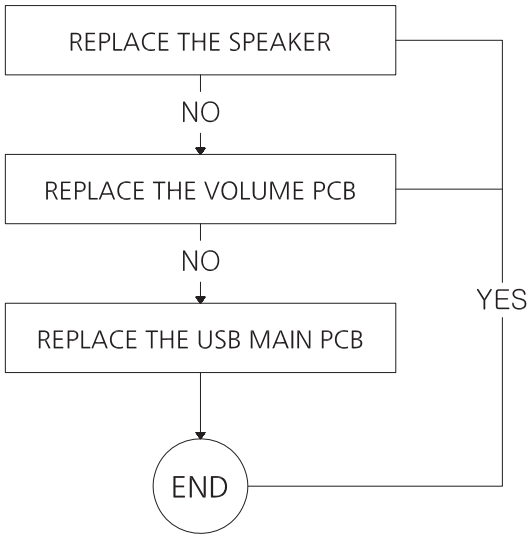

- CODE NO.
[MZZZ0SPE021]

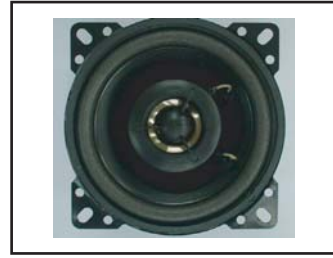

- CODE NO.
[AHM20PCB016]

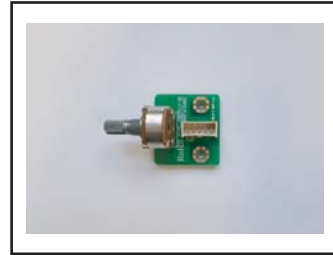

- CODE NO.
[AZZZ0PCB144]



6. EXPLODED VIEW

6-1. MAIN CABINET PART

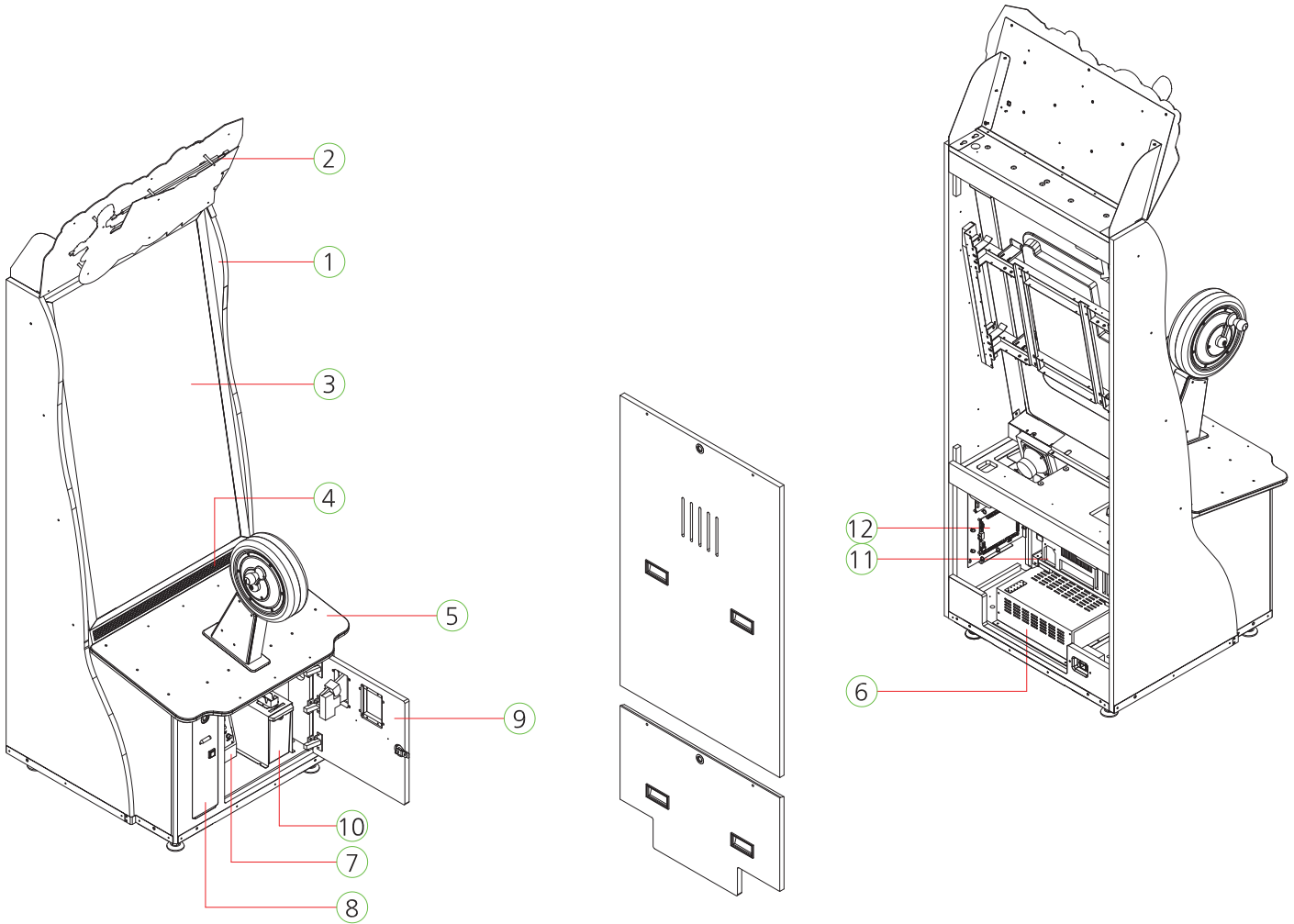

NO.	PART NAME	SPEC.	QUANTITY	CODE NO.
1	MAIN CABINET PART	-	1	-
2	BILLBOARD PART	-	1	-
3	MONITOR FRONT COVER PART	-	1	-
4	SPEAKER & MONITOR DECO FRAME PART	-	1	-
5	TABLE PANEL PART	-	1	-
6	SMPS PART	-	1	-
7	SERVICE PANEL PART	-	1	-
8	TICKET DISPENSER PART	-	1	-
9	FRONT DOOR PART	-	1	-
10	COIN BOX PART	-	1	-
11	MAIN BOX PART	-	1	-
12	CABINET PCB PART	-	1	-

6-2. BILLBOARD PART

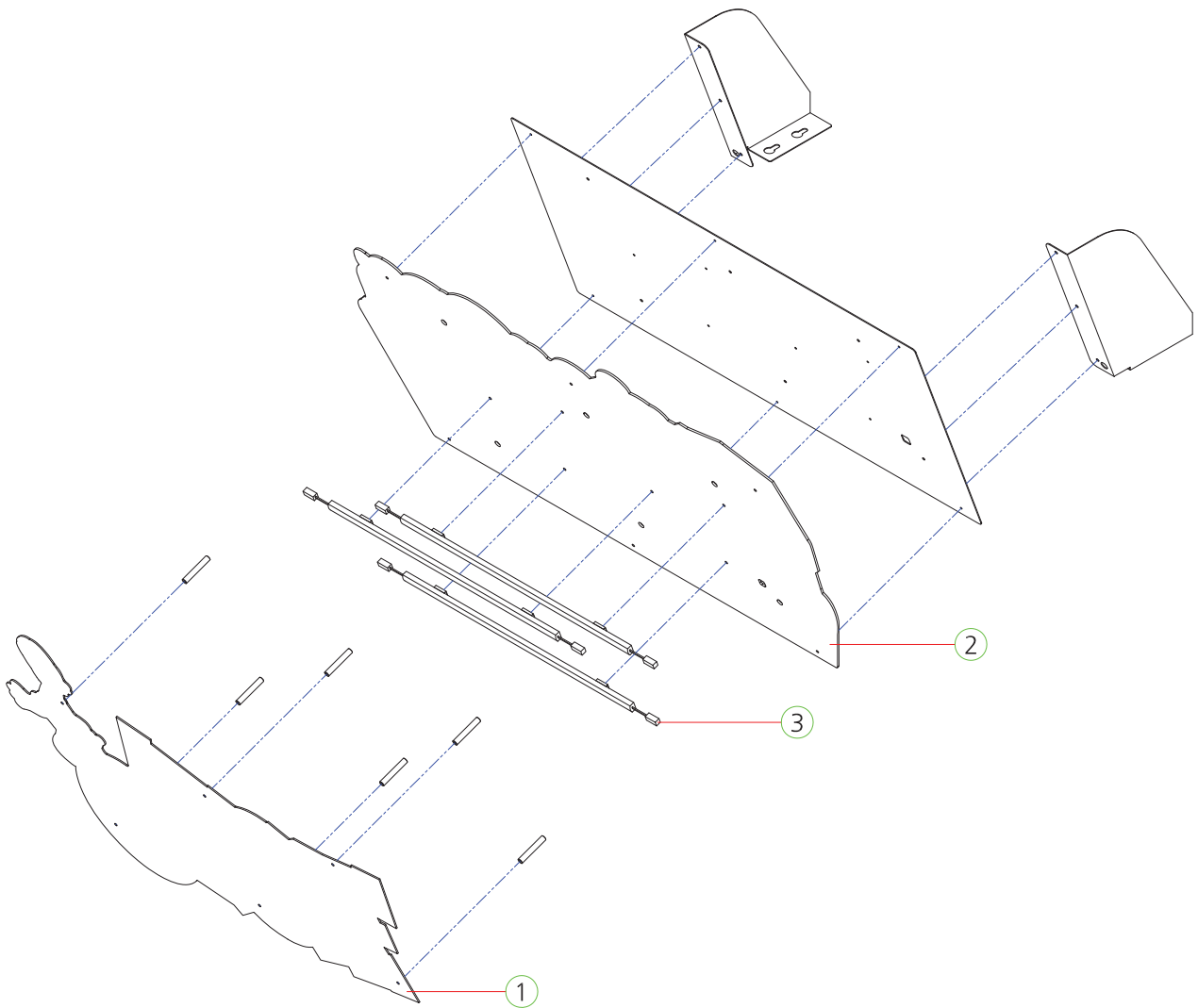

NO.	PART NAME	SPEC.	QUANTITY	CODE NO.
1	BILLBOARD FRONT COVER	PC-2.0T	1	MT1P0ACR003
2	BILLBOARD BACK BOARD	FORMAX-3.0T	1	MT1P0ACR011
3	LED BAR 12V ASS'Y	460mm	3	AZZZ0PCB124

6-3. MONITOR FRONT COVER PART

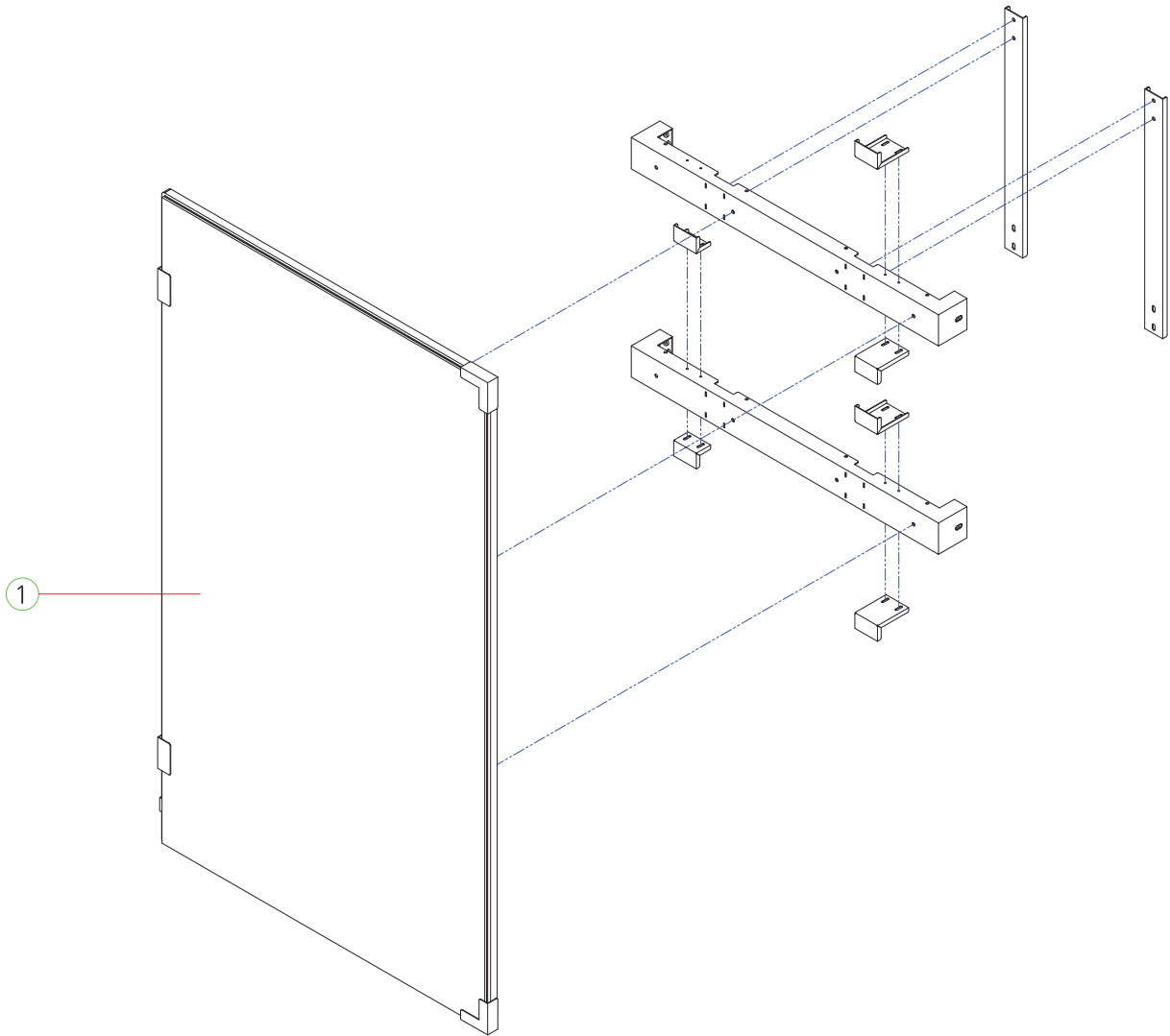

NO.	PART NAME	SPEC.	QUANTITY	CODE NO.
1	LED MONITOR	551213	1	MZZ0MON039

6-4. SPEAKER & MONITOR DECO FRAME PART

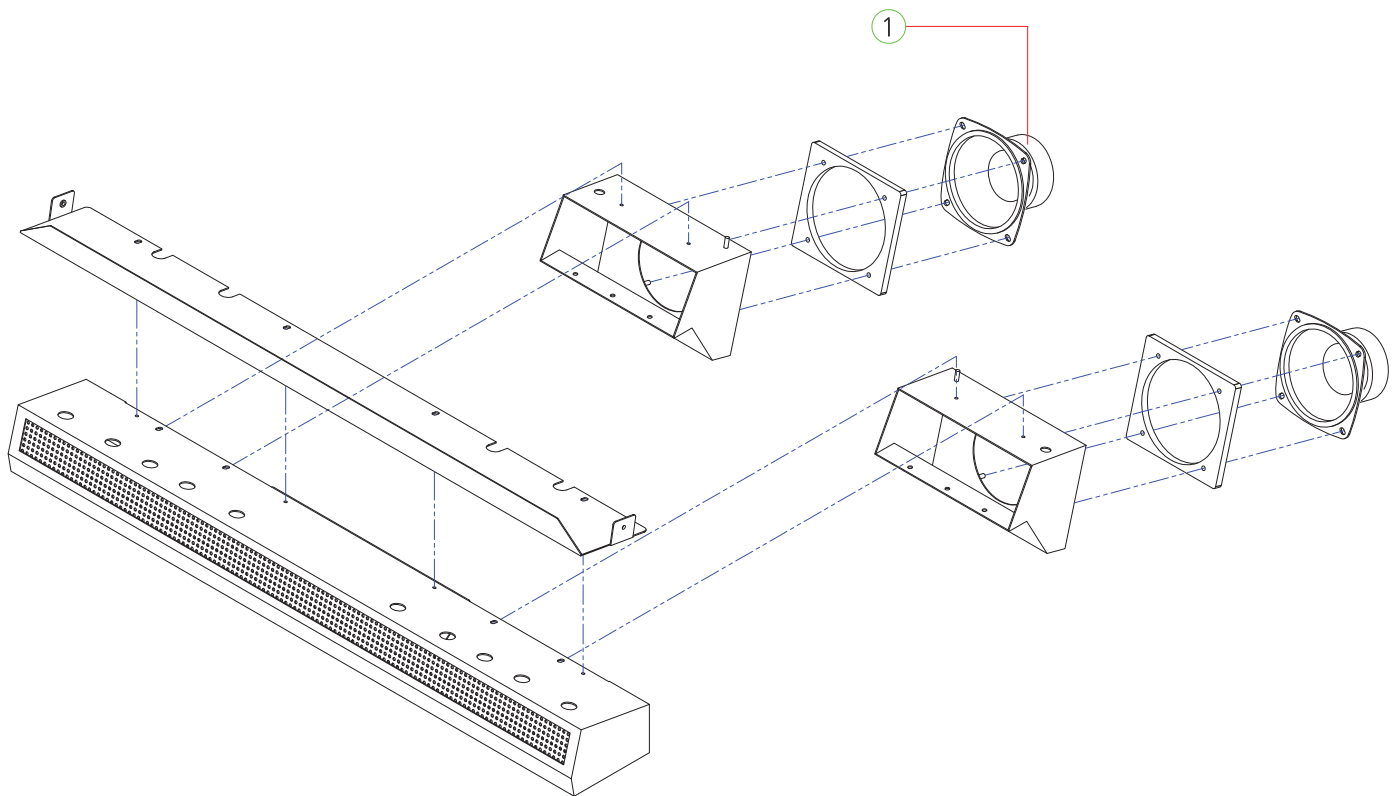

NO.	PART NAME	SPEC.	QUANTITY	CODE NO.
1	SPEAKER	MID4.5"+TW1/2" 8Ω	2	MZZZ0SPE021

6-5. TABLE PANEL PART

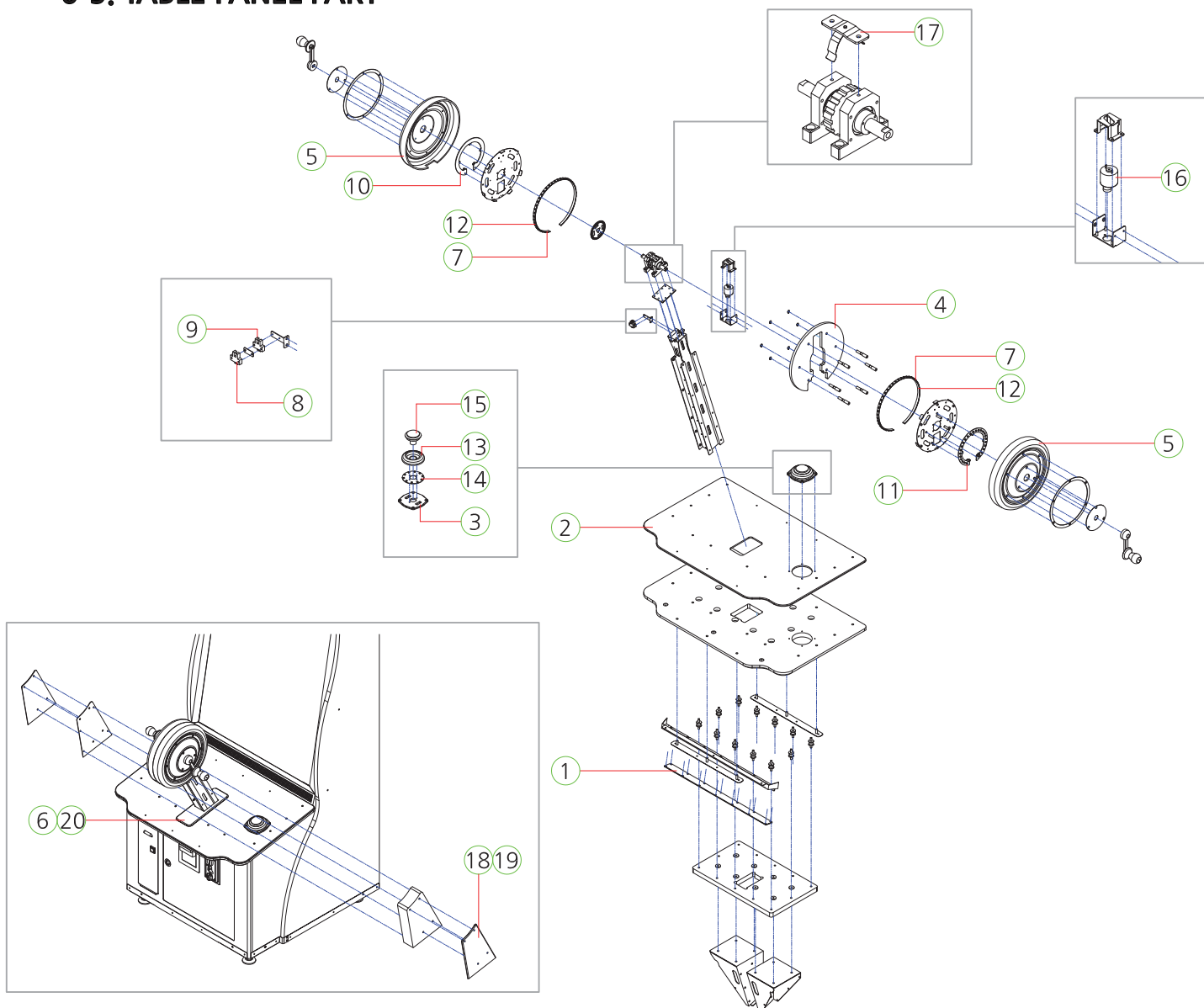

NO.	PART NAME	SPEC.	QUANTITY	CODE NO.
1	FRONT TABLE LED ACR COVER	ACRYL-3.0T	1	MT1P0ACR005
2	TABLE SHEET ACRYL PLATE	ACRYL-5.0T	1	MT1P0ACR006
3	FRONT TABLE BUTTON ACRYL	ACRYL-5.0T	1	MT1P0ACR004
4	CONTROLLER MOLD FIX ACRYL	ACRYL-10.0T	1	MTIROACR003
5	CONTROLLER COVER	PC-5.0T	2	MTIROPLA002
6	CONTROLLER PAD	ACRYL-3.0T	1	MT1P0ACR008
7	CONTROLLER LED SUPT	PET-1.0T	2	MTIROACR002
8	PHOTO SENSOR R	BS5-K2M_CT02 1M	1	AELEOPHO003
9	PHOTO SENSOR F	BS5-K2M_CT02 1M	1	AELEOPHO002
10	CONT SIDE LED L PCB ASS'Y	-	1	ATIROPCB001
11	CONT SIDE LED R PCB ASS'Y	-	1	ATIROPCB002
12	WS2813B FLEX LED	650mm	2	MELE0LED025
13	BUTTON HOUSING	φ85	1	MZZZ0PLA038
14	RGB BUTTON LED PCB ASS'Y	-	1	ASHS0PCB002
15	BUTTON ASS'Y	CL-2020 65 TYPE LED	1	MZZZ0BUT101
16	VIBRATION MOTOR ASS'Y	KD1-3429-075-001	1	MTIROASS004
17	TENSION GUIDE ASS'Y	-	1	ATIROASS007
18	CONTROLLER FRAME COVER ACRYL	ACRYL-5.0T	1	MT1P0ACR007
19	CONTROLLER FRAME COVER ACRYL [CEC]	ACRYL-5.0T	1	MT1P0ACR009
20	CONTROLLER PAD [CEC]	ACRYL-3.0T	1	MT1P0ACR008

6-6. SMPS PART

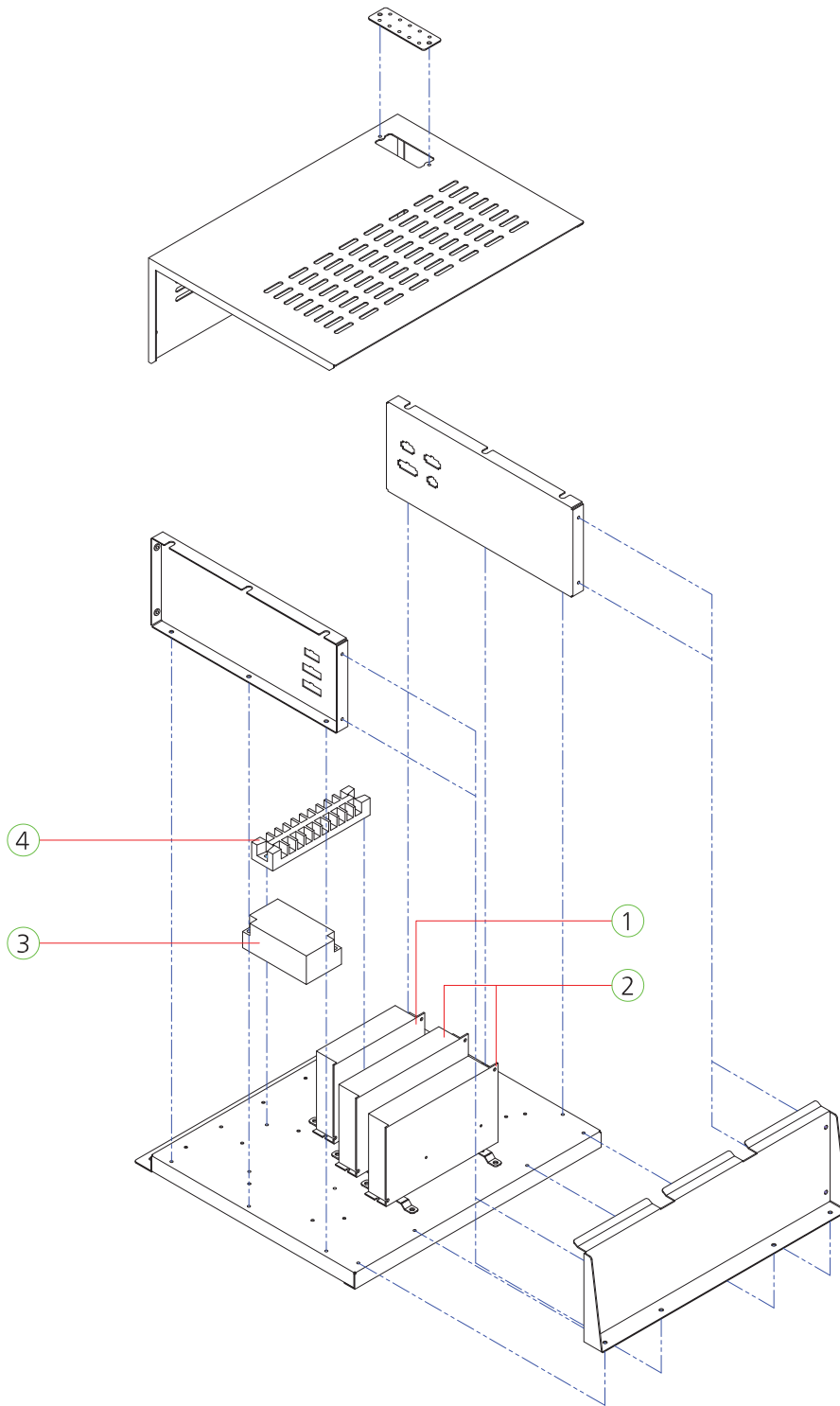

NO.	PART NAME	SPEC.	QUANTITY	CODE NO.
1	POWER SMPS	LRS-100-5	1	MELE0SMP095
2	POWER SMPS	LRS-150F-12	2	MELE0SMP090
3	NOISE FILTER	RNS-2010	1	MELE0NOI009
4	TERMINAL BLOCK	250V, 10P	1	MELE0TEB003

6-7. SERVICE PANEL PART

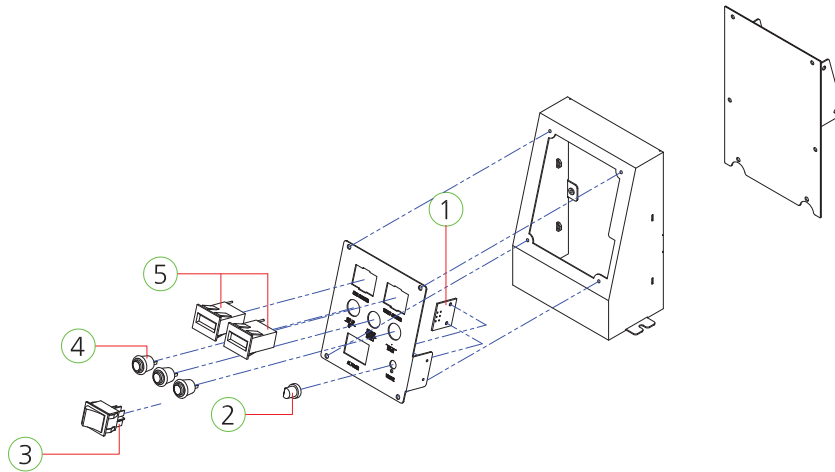

NO.	PART NAME	SPEC.	QUANTITY	CODE NO.
1	VOLUME PCB ASS'Y	1 VOLUME	1	AHM20PCB016
2	VOLUME KNOB	CAP BLUE	1	MELE0VOL007
3	ROCKER SWITCH	R595KDF	1	MELE0SWI021
4	PUSH BUTTON SWITCH	DS-412R ROSH	3	MELE0PUS006
5	COUNTER	OA127CL	2	MZZZ0COU002

6-8. TICKET DISPENSER PART

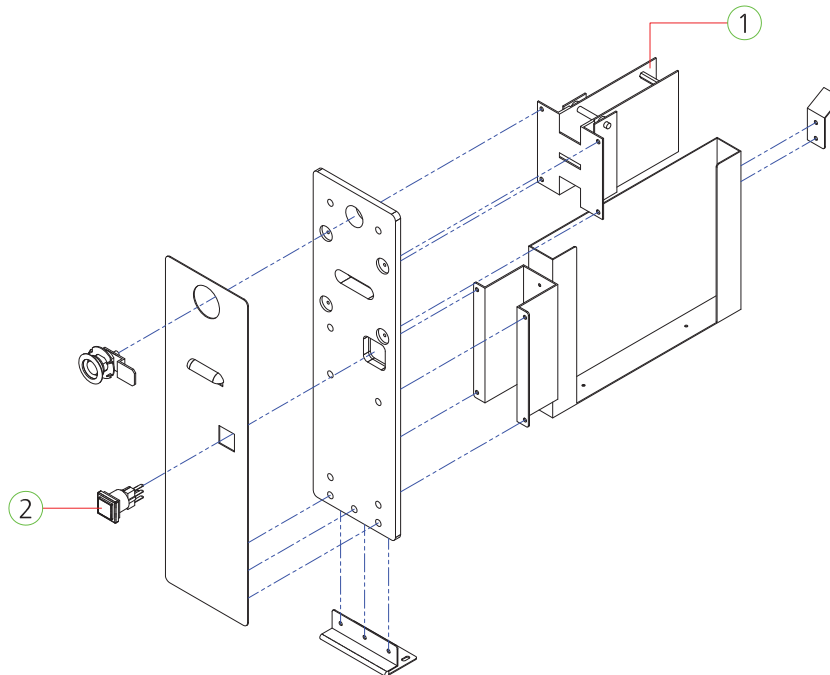

NO.	PART NAME	SPEC.	QUANTITY	CODE NO.
1	TICKET DISPENSOR	CLE CL-002Q	1	MZZZ0TID010
2	BUTTON SWITCH	TICKET AM1PB-26SH R12D	1	MMUM0BUT002

6-9. FRONT DOOR PART

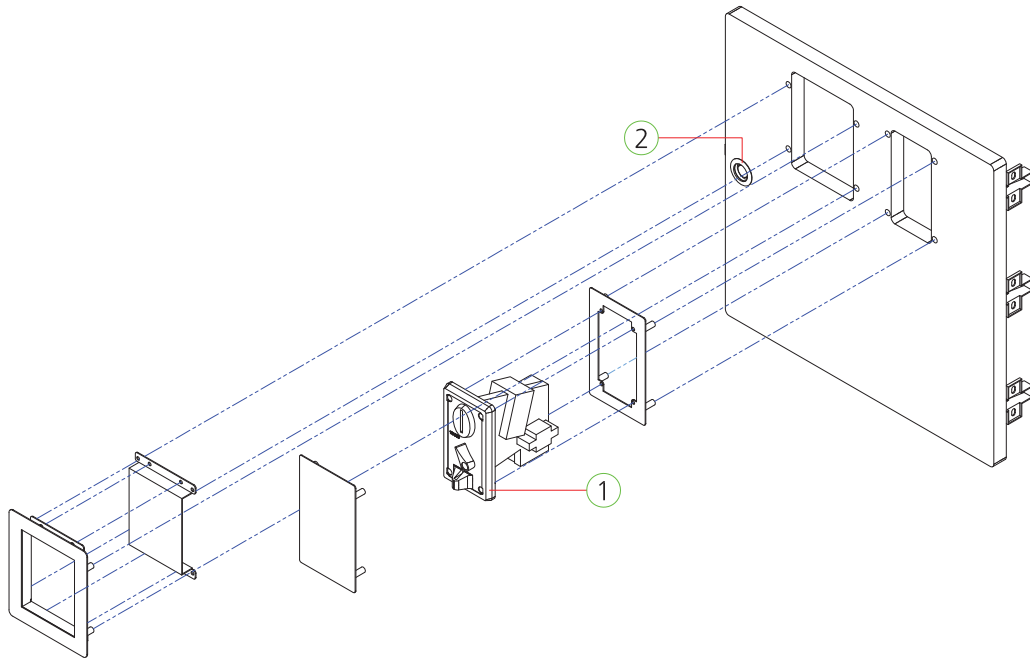

NO.	PART NAME	SPEC.	QUANTITY	CODE NO.
1	COIN SELECTOR	TW-389	1	MZZZ0COS052
2	KEY ASS'Y [INT]	7001	1	MZZZ0KEY076
3	KEY ASS'Y [CEC]	CEC	1	MZZZ0KEY069

6-10. COIN BOX PART

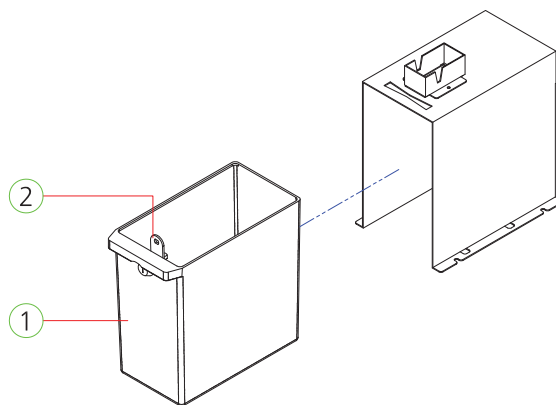

NO.	PART NAME	SPEC.	QUANTITY	CODE NO.
1	COIN BOX SMALL	BLACK	1	AZZZ0PLA012
2	KEY ASS'Y [INT]	6001	1	MZZZ0KEY075
3	KEY ASS'Y [CEC]	CEC	1	MZZZ0KEY069

6-11. MAIN BOX PART

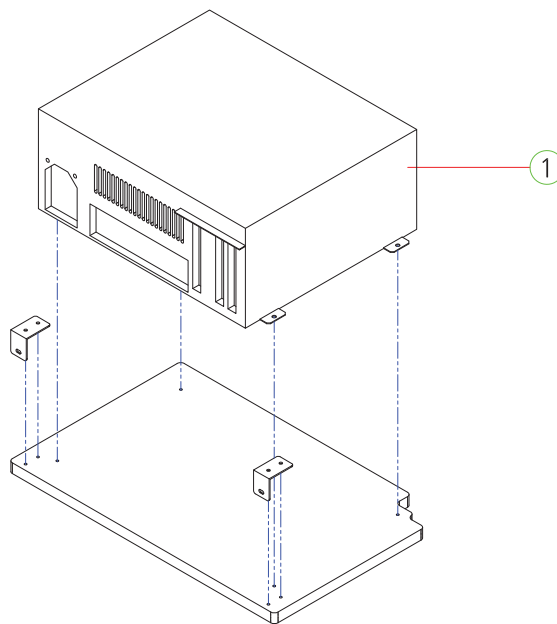

NO.	PART NAME	SPEC.	QUANTITY	CODE NO.
1	MK BOX ASS'Y	TIGHT ROPE	1	ATIR0SYS001



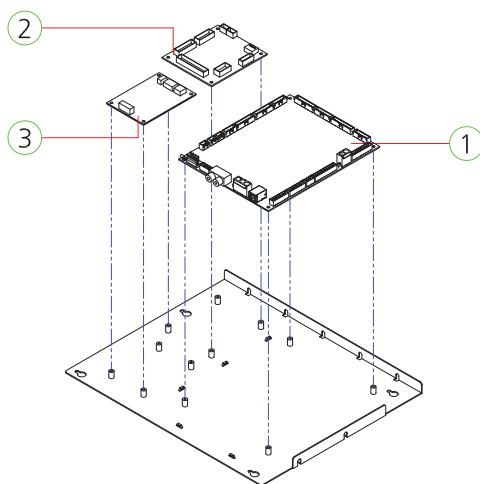



6-12. CABINET PCB PART



NO.	PART NAME	SPEC.	QUANTITY	CODE NO.
1	USB MAIN PCB ASS'Y	STAND IO	1	AZZ0PCB144
2	WS2812B IO PCB ASS'Y	-	1	AZZ0PCB152
3	NUVOTON MOTOR DRIVER 2CH PCB ASS'Y	20170612	1	AT1P0PCB001







7. PART PICTURE



NO.	PIC	PART NAME	SPEC.	QTY	CODE NO.	WARRANTY	
						6 Month	One Year
①	○	LED MONITOR	551213	1	MZZZ0MON039		○
②	○	SPEAKER	MID4.5"+TW1/2" 8Ω	2	MZZZ0SPE021	N / A	N / A
③	○	POWER SMPS	LRS-100-5	1	MELE0SMP095		○
④	○	POWER SMPS	LRS-150F-12	2	MELE0SMP090		○
⑤	○	NOISE FILTER	RNS-2010	1	MELE0NOI009	N / A	N / A
⑥	○	TERMINAL BLOCK	250V, 10P	1	MELE0TEB003	N / A	N / A
⑦	○	VOLUME PCB ASS'Y	1 VOLUME	1	AHM20PCB016		○
⑧	○	VOLUME KNOB	CAP BLUE	1	MELE0VOL007	N / A	N / A
⑨	○	ROCKER SWITCH	R595KDF	1	MELE0SWI021	N / A	N / A
⑩	○	PUSH BUTTON SWITCH	DS-412R ROSH	3	MELE0PUS006	N / A	N / A
⑪	○	COUNTER	OA127CL	2	MZZZ0COU002	N / A	N / A
⑫	○	TICKET DISPENSOR	CLE CL-002Q	1	MZZZ0TID010	N / A	N / A
⑬	○	BUTTON SWITCH	TICKET AM1PB-26SH R12D	1	MMUM0BUT002	N / A	N / A
⑭	○	PHOTO SENSOR R	BS5-K2M_CT02 1M	1	AELE0PHO003	○	
⑮	○	PHOTO SENSOR F	BS5-K2M_CT02 1M	1	AELE0PHO002	○	
⑯	○	CONT SIDE LED L PCB ASS'Y	-	1	ATIROPCB001		○
⑰	○	CONT SIDE LED R PCB ASS'Y	-	1	ATIROPCB002		○
⑱	○	BUTTON HOUSING	φ85	1	MZZZ0PLA038	N / A	N / A
⑲	○	RGB BUTTON LED PCB ASS'Y	-	1	ASHSOPCB002		○
⑳	○	BUTTON ASS'Y	CL-2020 65 TYPE LED	1	MZZZ0BUT101	N / A	N / A
㉑	○	VIBRATION MOTOR ASS'Y	KD1-3429-075-001	1	MTIROASS004	○	
㉒	○	COIN SELECTOR	TW-389	1	MZZZ0COS052	N / A	N / A
㉓	○	MK BOX ASS'Y	TIGHT ROPE	1	ATIROSYS001		○
㉔	○	USB MAIN PCB ASS'Y	STAND IO	1	AZZZ0PCB144		○
㉕	○	WS2812B IO PCB ASS'Y	-	1	AZZZ0PCB152		○
㉖	○	NUVOTON MOTOR DRIVER 2CH PCB ASS'Y	20170612	1	AT1P0PCB001		○
㉗	○	LED BAR 12V ASS'Y	460mm	3	AZZZ0PCB124	N / A	N / A

1	2	3	4	5	6
					
MZZ0MON036	MZZ0SPE021	MELE0SMP095	MELE0SMP090	MELE0NOI009	MELE0TEB003

7	8	9	10	11	12
					
AHM20PCB016	MELE0VOL007	MELE0SWI021	MELE0PUS006	MZZ0COU002	MZZ0TID010

13	14	15	16	17	18
					
MMUM0BUT002	AELE0PHO003	AELE0PHO002	ATIR0PCB001	ATIR0PCB002	MZZ0PLA038

19	20	21	22	23	24
					
ASHS0PCB002	MZZ0BUT101	MTIR0ASS004	MZZ0COS052	ATIR0SYS001	AZZZ0PCB144

25	26	27
		
AZZZ0PCB152	AT1P0PCB001	AZZZ0PCB124

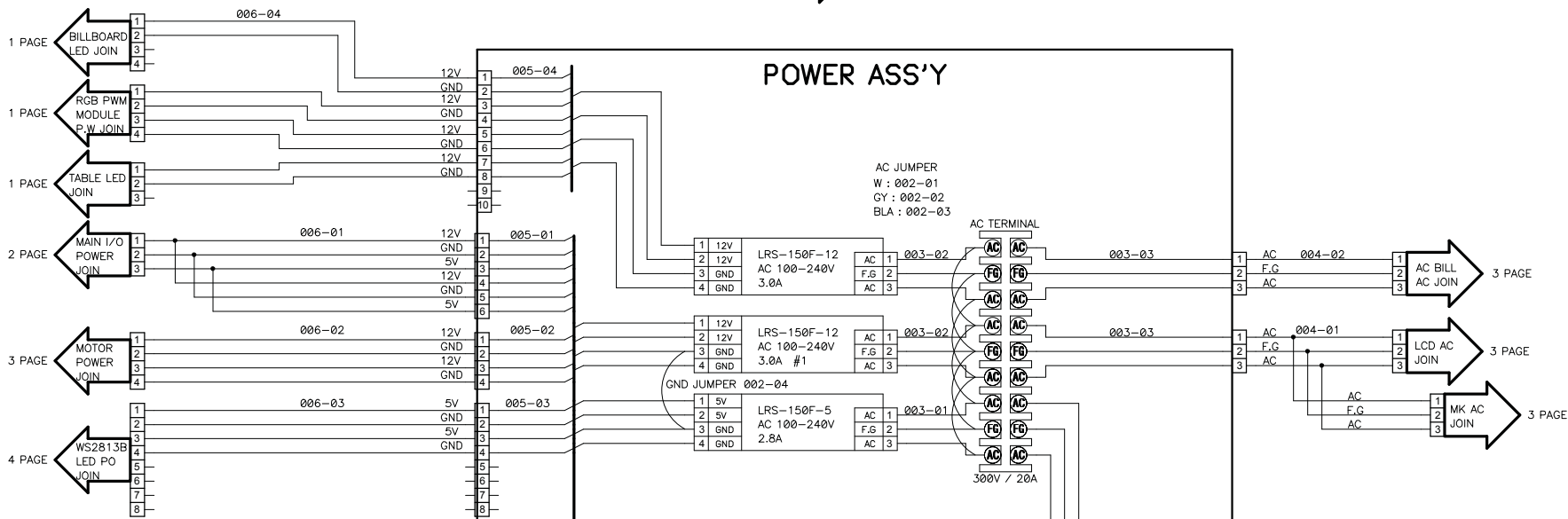
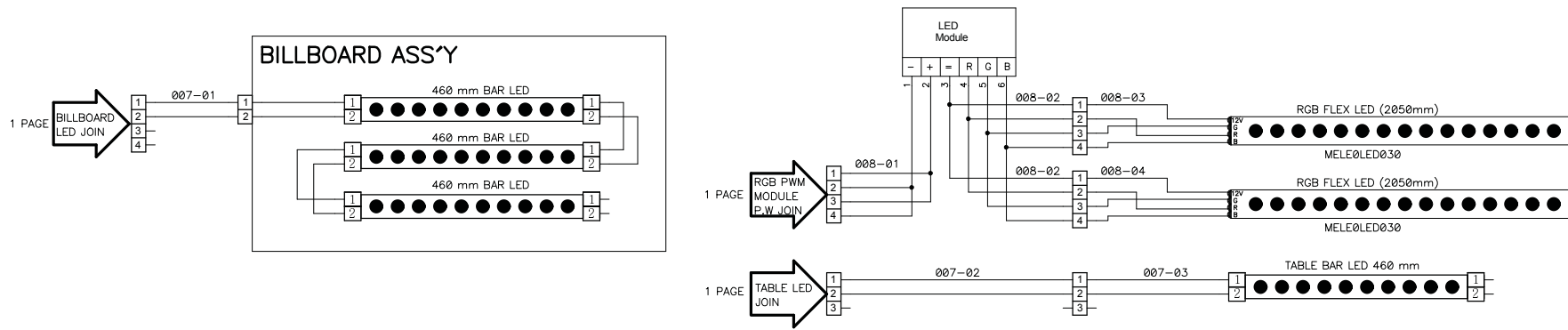

REPRODUCTION, DISTRIBUTION AND UTILIZATION OF THIS DOCUMENT AS WELL AS COMMUNICATION OF ITS CONTENTS TO OTHERS WITHOUT EXPRESS AUTHORIZATION PROHIBITED. OFFENDERS WILL BE HELD LIABLE FOR THE PAYMENT OF DAMAGES. ALL RIGHT RESERVED. COPYRIGHT (c) ANDAMIRO

(복제, 배포 및 사용은 물론, 명시적 허가 없이는 라인에게 내용을 전달할 수 없으며 위반자는 손해 배상 책임을 집니다.)

DEPARTMENT	DRAWN BY	CHECKED BY	APPROVED BY	ITEM	TIGHT LOPE 1P
H/W	H.B.KIM			PAGE	1 PAGE
				DATE	2017.12.04



USB MAIN PCB 1/2

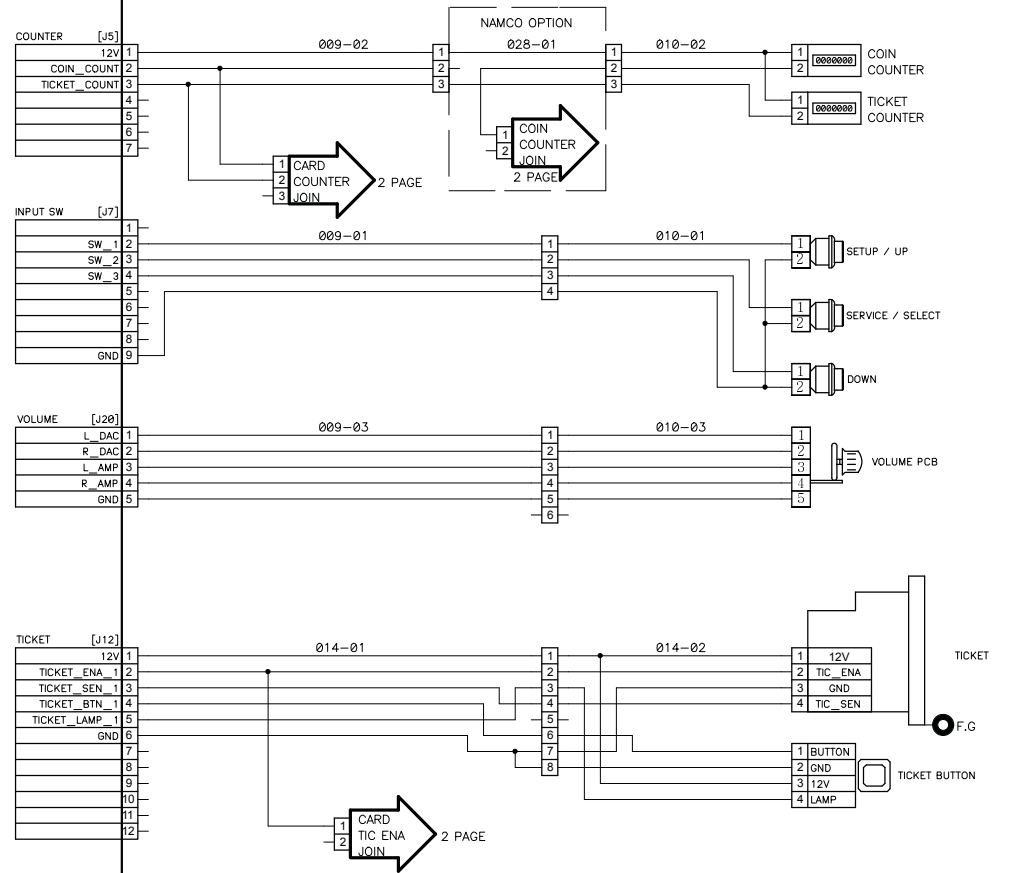
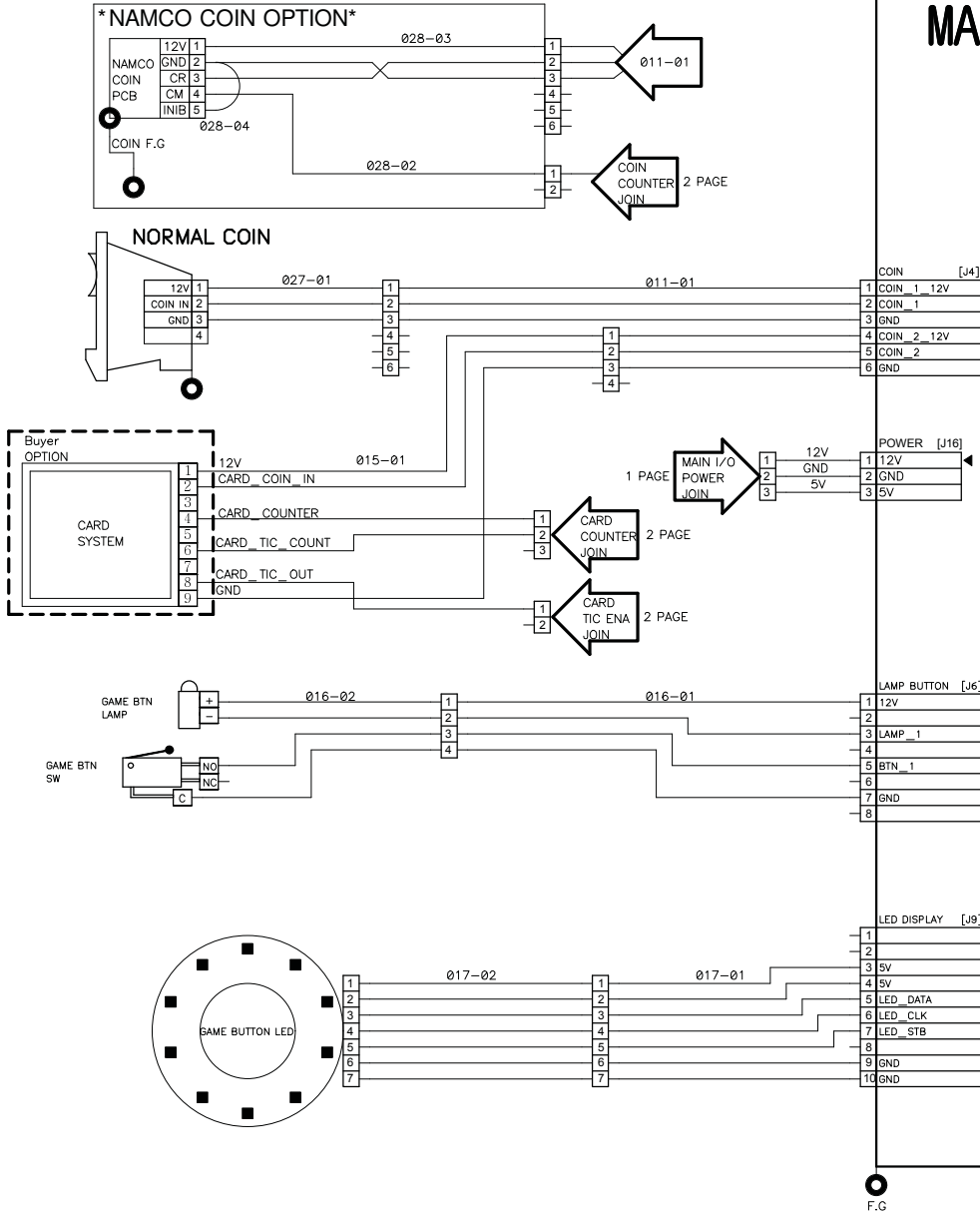

REPRODUCTION, DISTRIBUTION AND UTILIZATION OF THIS DOCUMENT AS WELL AS COMMUNICATION OF ITS CONTENTS TO OTHERS WITHOUT EXPRESS AUTHORIZATION PROHIBITED. OFFENDERS WILL BE HELD LIABLE FOR THE PAYMENT OF DAMAGES. ALL RIGHT RESERVED. COPYRIGHT (c) ANDAMIRO

(복제, 배포 및 사용은 물론, 명시적 허가 없이는 타인에게 내용을 전달할 수 없으며 위반자는 손해 배상 책임을 집니다.)

DEPARTMENT	DRAWN BY	CHECKED BY	APPROVED BY	ITEM	TIGHT LOPE 1P
H/W	H.B.KIM			PAGE	2 PAGE
				DATE	2017.12.04



USB MAIN PCB 2/2

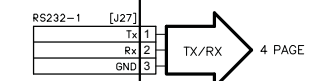
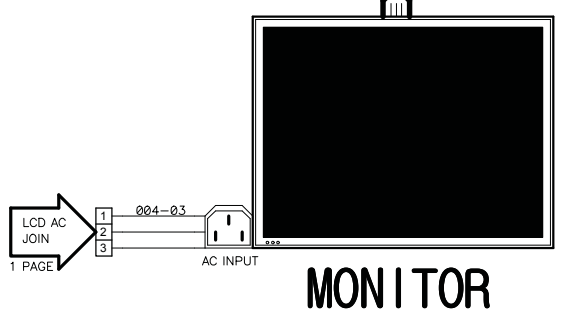
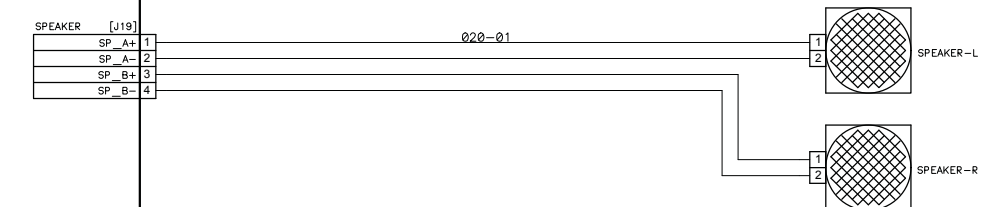
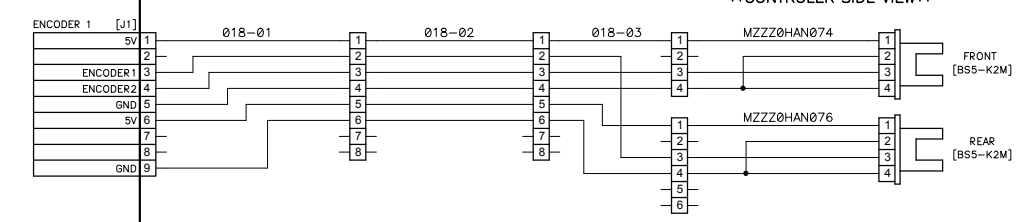
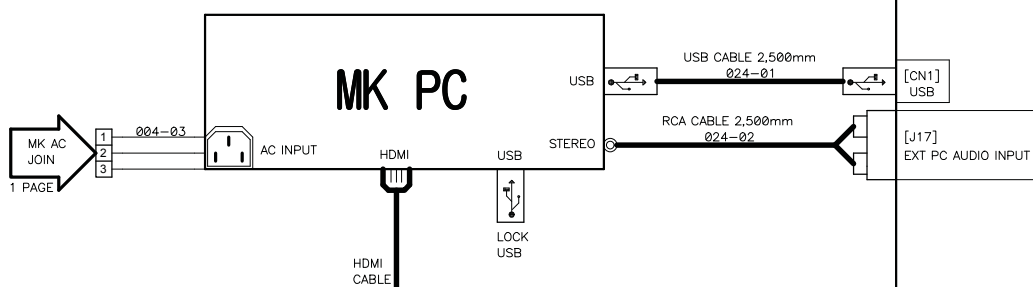
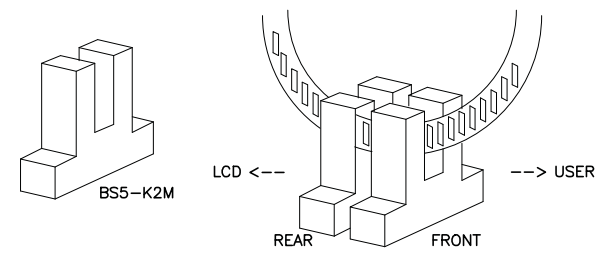
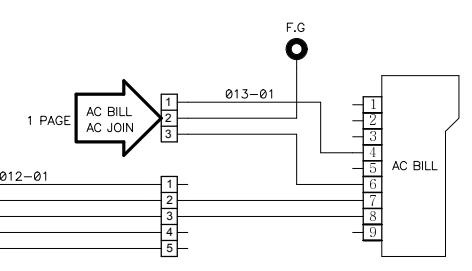
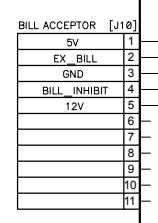
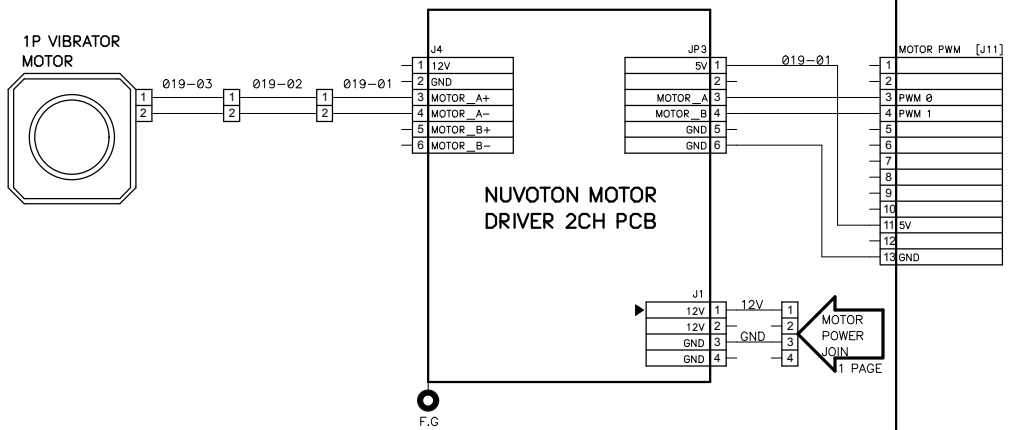

REPRODUCTION, DISTRIBUTION AND UTILIZATION OF THIS DOCUMENT AS WELL AS COMMUNICATION OF ITS CONTENTS TO OTHERS WITHOUT EXPRESS AUTHORIZATION PROHIBITED. OFFENDERS WILL BE HELD LIABLE FOR THE PAYMENT OF DAMAGES. ALL RIGHT RESERVED. COPYRIGHT (c) ANDAMIRO

(복제, 배포 및 사용은 물론, 명시적 허가 없이는 타인에게 내용을 전달할 수 없으며 위반자는 손해 배상 책임을 집니다.)

DEPARTMENT	DRAWN BY	CHECKED BY	APPROVED BY	ITEM	TIGHT LOPE 1P
H/W	H.B.KIM			PAGE	3 PAGE
ANDAMIRO				DATE	2017.12.04

WS2813B I/O PCB

1P CONTROLLER DISPLAY

WS2813B
LED PO
I/O IN
1 PAGE

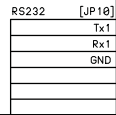
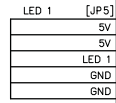
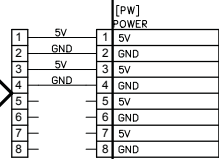

F.G

022-01

022-02

022-03

CONTROLLER SIDE
LED PCB-L

CONTROLLER SIDE
LED PCB-R

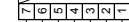
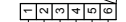
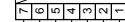
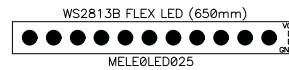

023-03

023-03

021-01

TX/RX

3 PAGE

REPRODUCTION, DISTRIBUTION AND UTILIZATION OF THIS DOCUMENT AS WELL AS COMMUNICATION OF ITS CONTENTS TO OTHERS WITHOUT EXPRESS AUTHORIZATION PROHIBITED. OFFENDERS WILL BE HELD LIABLE FOR THE PAYMENT OF DAMAGES. ALL RIGHT RESERVED. COPYRIGHT (c) ANDAMIRO

(복제, 배포 및 사용은 물론, 명시적 허가 없이는 타인에게 내용을 전달할 수 없으며 위반자는 손해 배상 책임을 집니다.)

DEPARTMENT

DRAWN BY

CHECKED BY

APPROVED BY

ITEM

TIGHT LOPE 1P

H/W

H.B.KIM

PAGE

4 PAGE

ANDAMIRO

DATE

2017.12.04



ANDAMIRO WARRANTY POLICY



Andamiro warrants to the original purchaser that all of its products will be free from defects in material and workmanship.

Andamiro warrants the parts from date of shipment as follows.

- **One Year Limited Warranty : Electronic Boards & Monitor**
- **6 Month Limited Warranty : Moving Parts**

For any key components within the warranty period, Andamiro will repair or replace defective components free of charge.

When placing a warranty request, the customer is requested to furnish the following information:

1. Name of the game.
2. Serial Number of the game.
3. A Detailed Description of the defect/s experienced.

This warranty does not apply to the defects caused due to misuse or abuse of the product.

Any alterations made to game or game parts will void this warranty.

For warranty details on our product range please visit our website, www.andamiro.com.

ANDAMIRO CO., LTD.
www.andamiro.com



Please complete the following request form to place a warranty request and send it to ANDAMIRO Korea either by fax (Fax No: +82-31-908-7548) or by e-mail. The e-mail address of the person in charge of each region is shown in our web-site, www.andamiro.com

For the on-line request, please visit our web-site, www.andamiro.com and click "Customer Service" and then click "Contact Us" in which you shall find the e-mail address of the person in charge of each region.

1. Company Name : _____

2. Mailing Address : _____

3. E-Mail Address : _____

4. Phone No : _____

5. Name of the person in charge : _____

6. Description of the product defects

6-1) Name of the Game : _____

6-2) Serial No : _____

6-3) Date of Purchase : _____

6-4) Detailed description of the product defects.

Remarks: If possible, please provide us with related photos and videos which will be greatly appreciated to verify the cause of the problem.



ANDAMIRO CO., LTD.

TEL : 82-31-909-2123~5

[ADDRESS OFFICE] 704-1 Techno Town, 138, Ilsan-ro, Ilsandong-gu, Goyang-si,
Gyeonggi-do, Republic of Korea 10442

[FACTORY] 72 Nochemgil, Ilsan-donggu Goyang-si, Gyonggi-do, 410-834 korea

USA BRANCH

ANDAMIRO USA CORP.

TEL : 1-310-767-5800

[ADDRESS] 17230 S. Main Street Gardena, California 90248 U.S.A.

Homepage <http://www.andamiro.com/>