





# SERVICE MANUAL



[ IMPORTANT ]

- ▶ Please read the manual carefully and keep it in mind before using this machine
- ▶ Put this manual within touch of your reference in anytime.

ISSUE DATE:Apr. 13, 2022

PRODUCT INFO	PART INFO	SUPPORT INFO	NEW PRODUCT INFO
			

※ QR(SUPPROT) - Leaflets, manuals, solution(error code,trouble shooting document, watch&solve)

# PRECAUTIONS FOR USE

The following safety precautions are given throughout this manual. They must be strictly followed to protect those who install, use or maintain this product as well as to protect players, visitors and property.

## For safety reasons.

- The following suggestions should be adhered to:



Disregarding could result in serious injury.



Disregarding could result in injury or product damage.

- The following graphic suggestions describe the types of precautions to be followed.



Indicates a care should be taken.



Forbidden.



Indicates a matter which must be performed.

- **Precautions to be followed:**

**Certain procedures require a qualified in-shop maintenance person or industry specialist.**

**For such instructions, a qualified person must take care of the jobs.**

- Otherwise an electric shock, machine trouble or a serious accident may result.
- Replacing the machine parts, inspecting and maintaining the machines and troubleshooting must be assigned only to a qualified in-shop maintenance person or industry specialist. This booklet gives instructions that hazardous jobs in particular must be handled by an industry specialist. Qualified in-shop maintenance person and industry specialist are defined as follows.

### **Qualified in-shop maintenance person**

- A service staff shall have experience in operations of game machines. The staff shall be responsible for assembly, installation, inspection and maintenance of the machine.

### **Industry specialist**

- An industry specialist must be engaged in designing, manufacturing, inspecting and servicing amusement machines. He or she must have an education in electrical, electronic and mechanical engineering and routinely maintain and repair amusement machines.

# PRECAUTIONS FOR USE

## WARNING

**Be sure to consult an industry specialist when setting up, moving or transporting this product.**

- This product should not be set up, moved or transported by any one other than an industry specialist.
- When installing this product, set the 4 leg levelers evenly on the floor and make sure that the product is installed stably in a horizontal position. Unstable installation may result in injury or accident.
- When installing this product, do not apply undue force on movable parts. Otherwise, injury and accident may result, or the product may be damaged.

**The machine for indoor usage only does not install outside.**



**Do not set the game machine up near emergency exits.**



**Protect the game machine from:**

- Rain or moisture.
- Direct sunlight.
- Direct heat from air-conditioning and heating equipment, etc..
- Hazardous flammable substances.
- Otherwise an accident or malfunction may result.



**Do not place containers holding chemicals or water on or near the game machine.**



**Do not place objects near the ventilating holes.**



**Do not bend the power cord by force or place heavy objects on it.**



**Never plug or unplug the power cord with wet hands.**



**Never unplug the game machine by pulling the power cord.**



## CAUTION

**Be sure to use indoor wiring within the specified voltage requirements. For extension cord, use the specified rating or more.**

**Be sure to use the attached power cord.**

**Never plug more than one cord at a time into the electrical receptacle.**



**Do not lay the power cord where people walk through.**



**Be sure to ground this product.**



**Do not exert excessive force when moving the machine.**



**For proper ventilation, keep the game machine 100mm(4") away from the walls.**

**Do not alter the system related dipswitch settings.**

# PRECAUTIONS FOR USE

## WARNING

If there is any abnormality such as smoke, bad smell or abnormal noise being emitted from the machine, immediately turn OFF the main power switch and unplug the power cord from the receptacle to stop operating it. 

- Using the machine in abnormal conditions could result in fire or accidents.

### In case of abnormality

1. Turn OFF the main power switch.
2. Unplug the power cord from the receptacle.
3. Contact your nearest dealer.

**Do not leave the power cord plugged in improperly or covered with dust.** 

- Doing so could result the power cord periodically.

## CAUTION

**Do not use this product anywhere other than industrial areas.** 

- Using in a residential area or an area next to a residential area could affect signal reception of radios, television sets, telephones and etc..
- Do not give shock the surface of glass products.

- Please do not play this game if
  - When you do drinking;
  - When your physical condition is not normal;
  - When you are in pregnancy;
  - When you have on a pulse controller;
  - When you have recently experienced a cramp or fainting away while watching TV.
- Avoid excessive force/shock while playing/moving the game.
- While do games, pay attention to surrounding.

**Do not plug or unplug the power cord with wet hands.** 

**In handling the power cord, follow the instructions below.** 

- |   |  |
|---|--|
| • Do not damage the power cord.           | • Do not modify the power cord.            |
| • Do not bend the power cord excessively. | • Do not twist the power cord.             |
| • Do not heat the power cord.             | • Do not pull the power cord.              |
| • Do not bind the power cord.             | • Do not stand on the power cord.          |
| • Do not sandwich the power cord.         | • Do not drive a nail into the power cord. |

**If the power cord or power plug becomes damaged, stop using the machine immediately and ask your nearest dealer to replace the parts.**

**\* Electromagnetic wave may cause unexpected noise from speaker.**



# PRECAUTIONS FOR USE

## WARNING

Be sure to turn OFF the main power switch and unplug the power cord from the receptacle before inspecting or cleaning the machine.



When replacing parts, be sure to use parts of the correct specifications. Never use parts other than the specified ones.



Opening inside the machine shall be done by machine specialist only as high electric current is being sent inside. For game machine with monitor, a care should be taken while opening its back door. If not, a damage to the inside parts or the monitor may occur.



If the sub power switch of the service panel is turned OFF without turning OFF the main power switch of the power supply unit, some parts in the units remain live. When opening the back door, be sure to turn OFF the main power switch and unplug the power cord from the receptacle.



Strictly refrain from disassembly and repair of parts which are not indicated in this manual, as well as settings and remodeling.



To clean the game machine, wipe it with a soft cloth dampened in a neutral detergent.

- Using thinner or other organic solvent or alcohol may decompose the material.
- Electrical shock or equipment failure could be caused by water entering the inside of the machine.

## CAUTION

Components in the game are sensitive to vibrations and impact. Care should be used when moving and transporting the game machine.



Be sure not to let the machine tip over.

Before moving the machine, be sure to turn OFF the main power switch, unplug the power cord from the receptacle and remove the power cord from the machine.



Before moving take the machine, off the levelers and move it on the casters.

Avoid excessive force while moving the machine.

.....

## PRECAUTIONS IN HANDLING

- When setting up, inspecting, maintaining, moving or transporting this product, follow the procedures and instructions set forth in this manual and perform such work safely.
- Do not set up, handle, inspect, maintain, move or transport this product under conditions equivalent to the condition of "WARNING" or "CAUTION" specified in this manual.
- If a new owner is to have this product as a result of transfer, and etc., be sure to give this manual to the new owner.

# PRÉCAUTION D'EMPLOI

Les consignes de sécurité suivantes sont données dans ce manuel. Elles doivent être strictement suivies pour protéger ceux qui les installent. Utiliser ou entretenir ce produit pour la sécurité des utilisateurs, des visiteurs et des biens.

Pour des raisons de sécurité.

- **Les suggestions suivantes doivent être respectées:**

## **ATTENTION**

Le non-respect peut entraîner des blessures graves.

## **PRUDENCE**

Le non-respect peut entraîner des blessures ou des dommages au produit.

- **Les suggestions graphiques suivantes décrivent les types de précautions à prendre.**



Indique qu'attention est requise.



Interdit.



Indique que quelque chose doit être effectuée.

- **Les précautions à prendre :**

**Certaines procédures exigent une personne de maintenance qualifiée en atelier ou un spécialiste de l'industrie. Pour ces instructions, une personne qualifiée doit prendre soin des travaux.**

- Sinon, un choc électrique, un dysfonctionnement de la machine, ou un accident grave peut en résulter.
- Remplacement des pièces de machines, l'inspection et la maintenance des machines, et le dépannage doit être attribué qu'à une personne de maintenance qualifiée en atelier ou spécialiste de l'industrie. Cette brochure donne des instructions que les emplois dangereux, en particulier, doivent être traités par un spécialiste de l'industrie. La personne de maintenance qualifiée en atelier et le spécialiste de l'industrie sont définis comme suit.

### **La personne de maintenance qualifiée en atelier**

- Un personnel de service doit avoir de l'expérience dans les opérations de machines de jeux. Le personnel est responsable pour l'assemblage, l'installation, l'inspection et l'entretien de la machine.

### **Le spécialiste de l'industrie**

- Un spécialiste de l'industrie doit être engagé dans la conception, la fabrication, l'inspection et l'entretien des appareils d'amusement.  
Il ou elle doit avoir une formation en génie électrique, électronique et mécanique, et de maintenir régulièrement et de réparer les appareils d'amusement.

# PRÉCAUTION D'EMPLOI

## ATTENTION

Si il y a une anomalie comme fumée, mauvaise odeur ou bruit anormal émis par la machine,  couper immédiatement l'interrupteur principal et débranchez le câble d'alimentation de la prise pour arrêter son fonctionnement.

- L'utilisation de l'appareil dans des conditions anormales peut provoquer un incendie ou un accident.

En cas d'anomalie

1. Mettez l'interrupteur principal sur ARRÊT.
2. Débranchez le câble d'alimentation de la prise.
3. Contactez votre revendeur le plus proche.

**Ne pas brancher le câble d'alimentation incorrectement ou le laisser être recouvert de poussière.** 

Cela pourrait nuire le câble d'alimentation.

## PRUDENCE

**Ne pas utiliser ce produit ailleurs que dans les zones industrielles.** 

- L'utiliser dans une zone résidentielle ou d'une zone à côté d'un quartier résidentiel pourrait nuire à la réception des radios, téléviseurs, téléphones, etc.
- Ne donnez pas de choc à la surface d'un produit en verre.

- S'il vous plaît ne pas jouer à ce jeu.
  - Quand vous buvez;
  - Lorsque votre condition physique n'est pas normale;
  - Lorsque vous êtes dans une période de grossesse;
  - Lorsque vous avez un contrôleur d'impulsion;
  - Lorsque vous avez récemment subi une crampe ou évanouissement en regardant la télévision.
- Évitez une force excessive / un choc pendant la lecture / de déplacer le jeu.
- Quand vous jouez les jeux, faites attention aux alentours.

**Ne pas brancher ou débrancher le câble d'alimentation avec les mains mouillées.** 

**Dans la manipulation du câble d'alimentation, suivez les instructions ci-dessous.** 

- |  |   |
|--|---|
| • Ne pas endommager le câble d'alimentation.                 | • Ne pas modifier le câble d'alimentation.            |
| • Ne pas plier le câble d'alimentation de manière excessive. | • Ne tordez pas le câble d'alimentation.              |
| • Ne pas chauffer le câble d'alimentation.                   | • Ne tirez pas sur le câble d'alimentation.           |
| • Ne pas lier le câble d'alimentation.                       | • Ne montez pas sur le câble d'alimentation.          |
| • Ne pas prendre en sandwich le câble d'alimentation.        | • Ne pas mettre un clou dans le câble d'alimentation. |

**Si la fiche du câble d'alimentation ou est endommagé, cessez immédiatement d'utiliser la machine et demandez à votre revendeur le plus proche de remplacer les pièces.**

# PRÉCAUTION D'EMPLOI

## ⚠ ATTENTION

**Assurez-vous de consulter un spécialiste de l'industrie lors de la mise en place, du déplacement ou le transport de ce produit.**

- Ce produit ne doit pas être mis en place, déplacé ou transporté par une quelconque autre qu'un spécialiste de l'industrie.
- Lors de l'installation de ce produit, installez 4 niveleurs de pieds uniformément sur le sol et assurez-vous que le produit est installé de façon stable dans une position horizontale. Une installation instable peut entraîner des blessures ou un accident.
- Lors de l'installation de ce produit, ne pas appliquer une force excessive sur les pièces mobiles. Sinon, des blessures et des accidents peuvent y résulter, ou le produit peut être endommagé.

**La machine pour une utilisation en intérieur uniquement, ne pas installer à l'extérieur.**



**N'installez pas la machine de jeu près des issues de secours.**



**Protéger la machine de jeu de:**



- L'humidité ou la pluie.
- La lumière directe du soleil.
- La chaleur directe de la climatisation et du chauffage, etc...
- Des substances inflammables dangereuses.
- Sinon, un accident ou un dysfonctionnement.

**Ne pas placer les récipients contenant des produits chimiques ou de l'eau sur ou près de la machine de jeu.**



**Ne placez pas d'objets à proximité des orifices de ventilation.**



**Ne pas plier le cordon d'alimentation par la force ou de placer des objets lourds au-dessus.**



**Ne jamais brancher ou débrancher le cordon d'alimentation avec les mains mouillées.**



**Ne jamais débrancher la machine de jeu en tirant le câble d'alimentation.**



## ⚠ PRUDENCE

**Veillez à utiliser le câblage intérieur selon les exigences de tension spécifiées. Pour une rallonge, utilisez la notation spécifiée ou plus.**

**Veillez à utiliser le cordon d'alimentation fourni.**

**Ne jamais brancher plus d'un cordon à la fois dans la prise électrique.**



**Ne pas poser le cordon d'alimentation où les gens marchent à travers.**



**Soyez sûr de mettre à la terre ce produit.**



**Ne pas exercer une force excessive lors du déplacement de la machine.**





**Pour une ventilation correcte, garder la machine de jeu 100mm (4 ") loin des murs.**

**Ne pas modifier les réglages des commutateurs DIP liées au système.**

# PRÉCAUTION D'EMPLOI

## ⚠ ATTENTION

Veillez à éteindre l'interrupteur d'alimentation principale et débranchez le cordon d'alimentation de la prise avant d'inspecter ou de nettoyer la machine. 

Lors du remplacement des pièces, veillez à utiliser une partie des spécifications correctes. Ne jamais utiliser de pièces autres que celles spécifiées. 

L'ouverture à l'intérieur de la machine doit être effectuée par le spécialiste de la machine seulement, comme le courant électrique élevé est transmis à l'intérieur. Pour la machine de jeu avec le moniteur, un soin doit être pris lors de l'ouverture de sa porte arrière. Si non, une détérioration des pièces à l'intérieur ou à l'écran peut se produire. 

Si l'interrupteur secondaire du panneau de service est éteint sans éteindre le commutateur d'alimentation principale de l'unité d'alimentation, certaines parties dans les unités restent sous tension. Lors de l'ouverture de la porte arrière, veillez à éteindre l'interrupteur d'alimentation principale et débranchez le cordon d'alimentation de la prise. 

Il est strictement conseillé de s'abstenir de démonter et de réparer des pièces qui ne sont pas indiqués dans ce manuel, ainsi que les paramètres et le remodelage. 

Pour nettoyer la machine de jeu, l'essuyer avec un chiffon doux imbibé avec un détergent neutre.

- L'utilisation plus mince d'un autre solvant organique ou de l'alcool peut décomposer le matériel.
- Un choc électrique ou une défaillance de l'équipement pourraient être causés par la pénétration de l'eau à l'intérieur de la machine.

## ⚠ PRUDENCE

Les composants de la machine de jeu sont sensibles aux vibrations et aux chocs. Il faut faire attention lors du déplacement et le transport de la machine de jeu. 

Veillez à ne pas laisser la machine se renverser.

Avant de déplacer la machine, veillez à éteindre l'interrupteur d'alimentation principale, débranchez le cordon d'alimentation de la prise et débranchez le cordon d'alimentation de la machine. 

Avant de déplacer la machine, la mettre hors des niveleurs et le déplacer sur les roulettes.

Éviter une force excessive lors du déplacement de la machine.

.....

## PRÉCAUTIONS LORS DU MANIEMENT

- Lors de la mise en place, l'inspection, l'entretien, déplacement ou le transport de ce produit, suivez les procédures et les instructions énoncées dans ce manuel et effectuer ce travail en toute sécurité.
- Ne pas mettre en place, manipuler, inspecter, entretenir, déplacer ou transporter ce produit dans des conditions équivalentes à l'état de "ATTENTION" ou "PRUDENCE" spécifiée dans ce manuel.
- Si un nouveau propriétaire obtient ce produit à la suite d'un transfert, etc., soyez sûr de donner ce manuel au nouveau propriétaire.

# CONTENTS

---

1	SPECIFICATION AND DIMENSION	PAGE
1)	DIMENSION .....	P02
2)	SPECIFICATION .....	P02
3)	STICKER LOCATION .....	P03
2	INSTALL INFORMATION	
	INSTALLATION SPACE,KEEP THE PRODUCT HORIZONTAL .....	P04
3	UNPACKING	
1)	PACKING LOCATION .....	P04
2)	COMPONENTS .....	P05
4	INSTALL	
1)	HOW TO INSTALL(BILLBOARD).....	P06
5	SETUP SETTINGS	
1 )	SETUP BUTTON LAYOUT, 2) MACHINE SETUP, 3) TEST MODE .....	P07
4)	TEST MODE - I/O TEST, 5) TEST MODE - SCREEN TEST .....	P08
6)	GAME SETTING, 7) CREDIT SETTING,8) TICKET SETTING .....	P09
9)	SOUND SETTING, 10) BOOKKEEPING,11) STATISTICS .....	P10
12)	STATISTICS - SINGLE MODE .....	P11
6	MAINTENANCE .....	P11
7	SOLUTION	
▶	ERROR CODE .....	P12
▶	TROUBLESHOOTING	
	[E.02] [E.21] [E.22] [E.23] [NO SIGNAL] .....	P13~16
8	EXPLODED VIEW	
▶	FULL DESCRIPTION .....	P17
▶	DETAILED EXPLANATION .....	P18~23
9	PCB CONNETCOR LOCATION	
1 )	BHB IO PCB ASS'Y, 2) ANDROID MAIN PCB ASS'Y .....	P24
3 )	WS2813B IO PCB ASS'Y .....	P25
10	BLOCK DIAGRAM . .....	P26

# 1 SPECIFICATION AND DIMENSION

## 1) DIMENSION

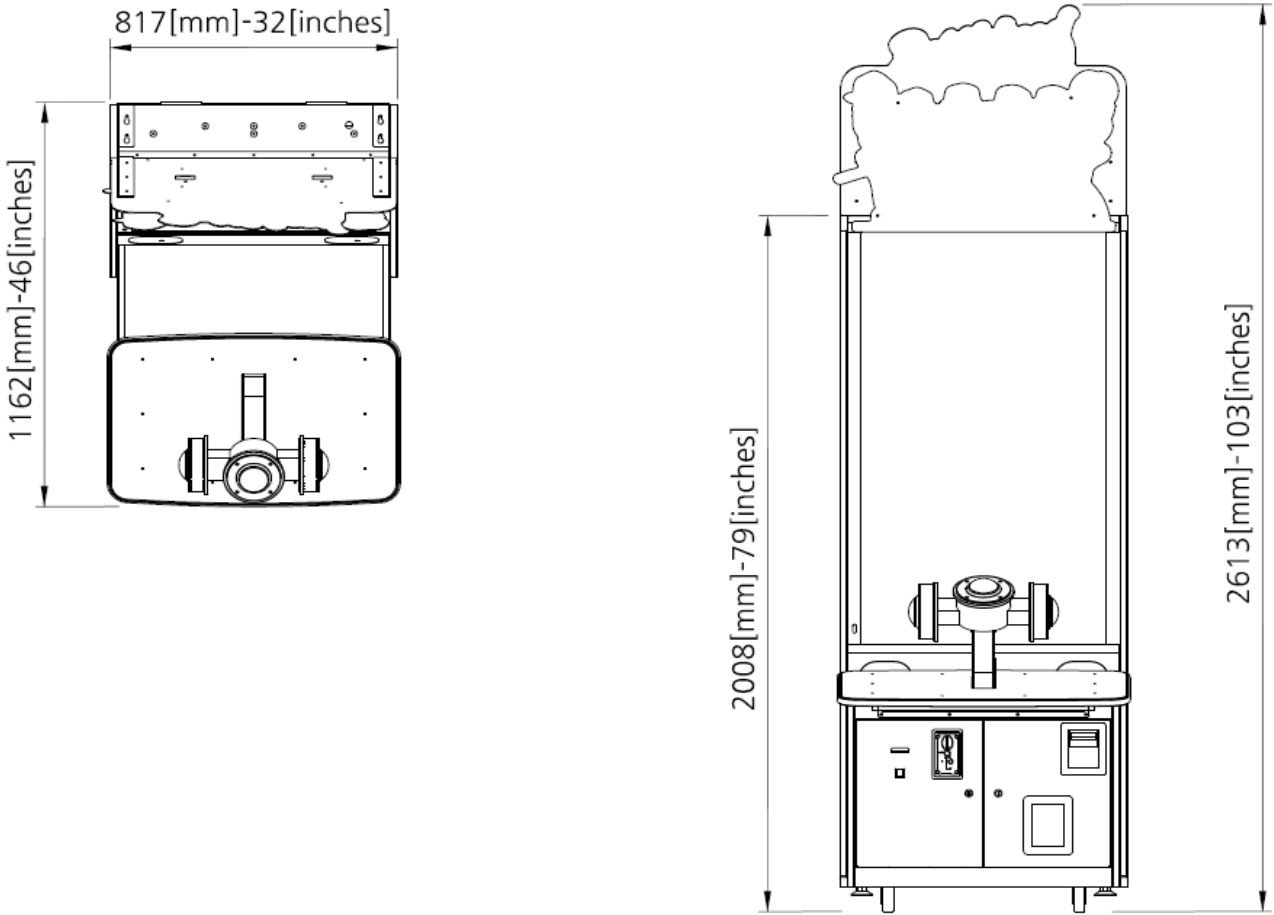

## 2) SPECIFICATION

ITEM	DETAILS	
VOLTAGE	AC 120V	AC 230V
FREQUENCY RANGE	60 Hz	50/60 Hz
CONSUMPTION	250 W	
INSTALL DIMENSION(W*D*H)	817*1162*2613mm, 32*46*103 inch	
PACKING DIMENSION(W*D*H)	1320*910*2250mm, 52*36*89 inch	
WEIGHT(kg), PACKING WEIGHT(kg)	155 kg, 182 kg	
CERTIFICATION	ETL	CE
*NOTE :NOTE : This product is a free bolt product.( AC 120-230V )		



3) STICKER LOCATION

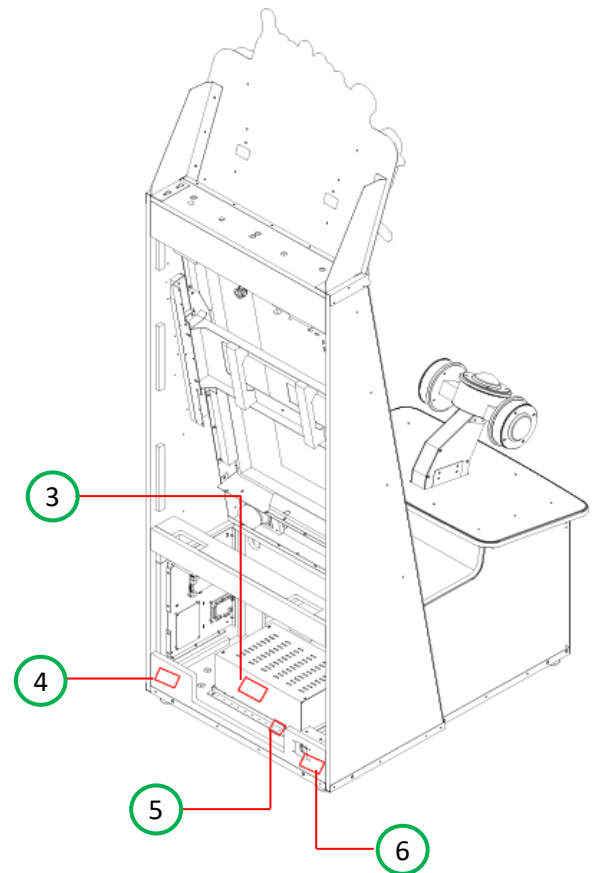
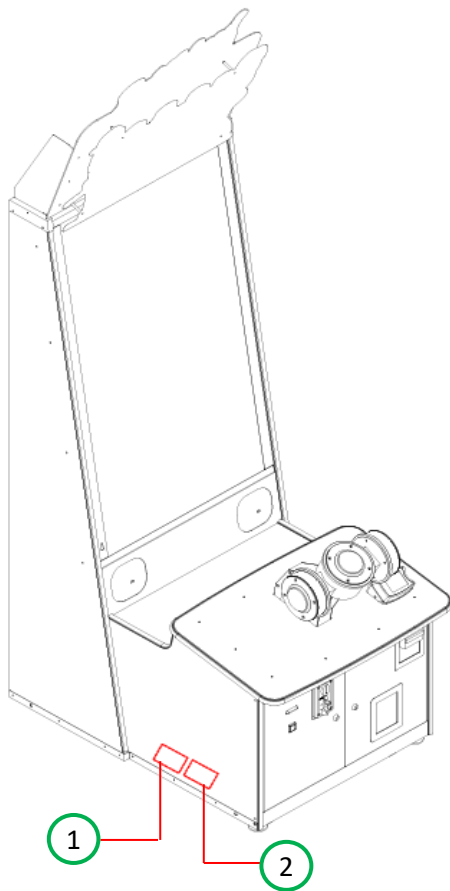

▼ 1	▼ 2	▼ 3
▼ 4	▼ 5	▼ 6
<p>Certification Label</p>		

## 2 INSTALL INFORMATION

### 1) INSTALLATION SPACE

- ※ Maintenance zone & Play zone should have at least 1200 mm(47 inch) \* 1700mm(67inch) each

### 2) MAINTAIN PRODUCT FLATNESS

- ※ After installation is complete
  - ※ 2-1 After securing space, adjust the 4 adjuster so that the product is stably leveled.

### 3) IMPORTANCE

- ※ This product should be indoor use and out of direct sunlight.

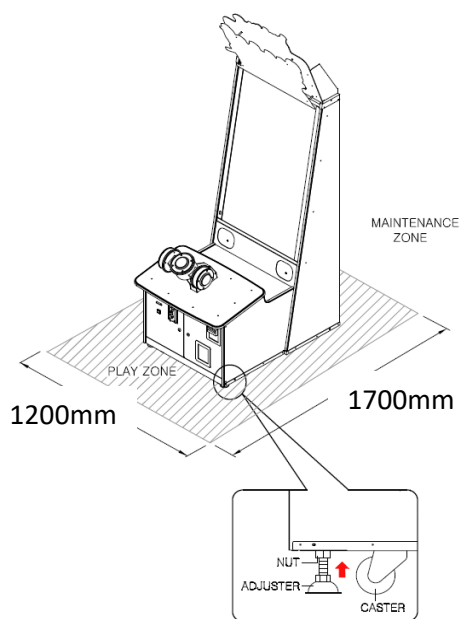









## 3 UNPACKING

### 1) PACKING LOCATION

PRODUCT		BILLBOARD BOX		
▼ 1	▼ 2	▼ 3	▼ 4	▼ 5
	COMPONENT ENVELOPE			

2) COMPONENTS

no	PART NAME	Q'TY	SPARE
1	AC CORD	1	
2	MANUAL	1	
3	ERROR COED	1	
4	RENCH 2.5, 3, 4, 5 MM	1 EACH	
5	KEY	1	
6	SCREW – TH_NI M4x8L	10	2
7	SCREW – TH_NI M6x25L	4	2

▼ 1	▼ 2	▼ 3	▼ 4	▼ 5	▼ 6, 7
					
▼ 8	▼ 9				
					

## 4 INSTALL

### 1) HOW TO INSTALL

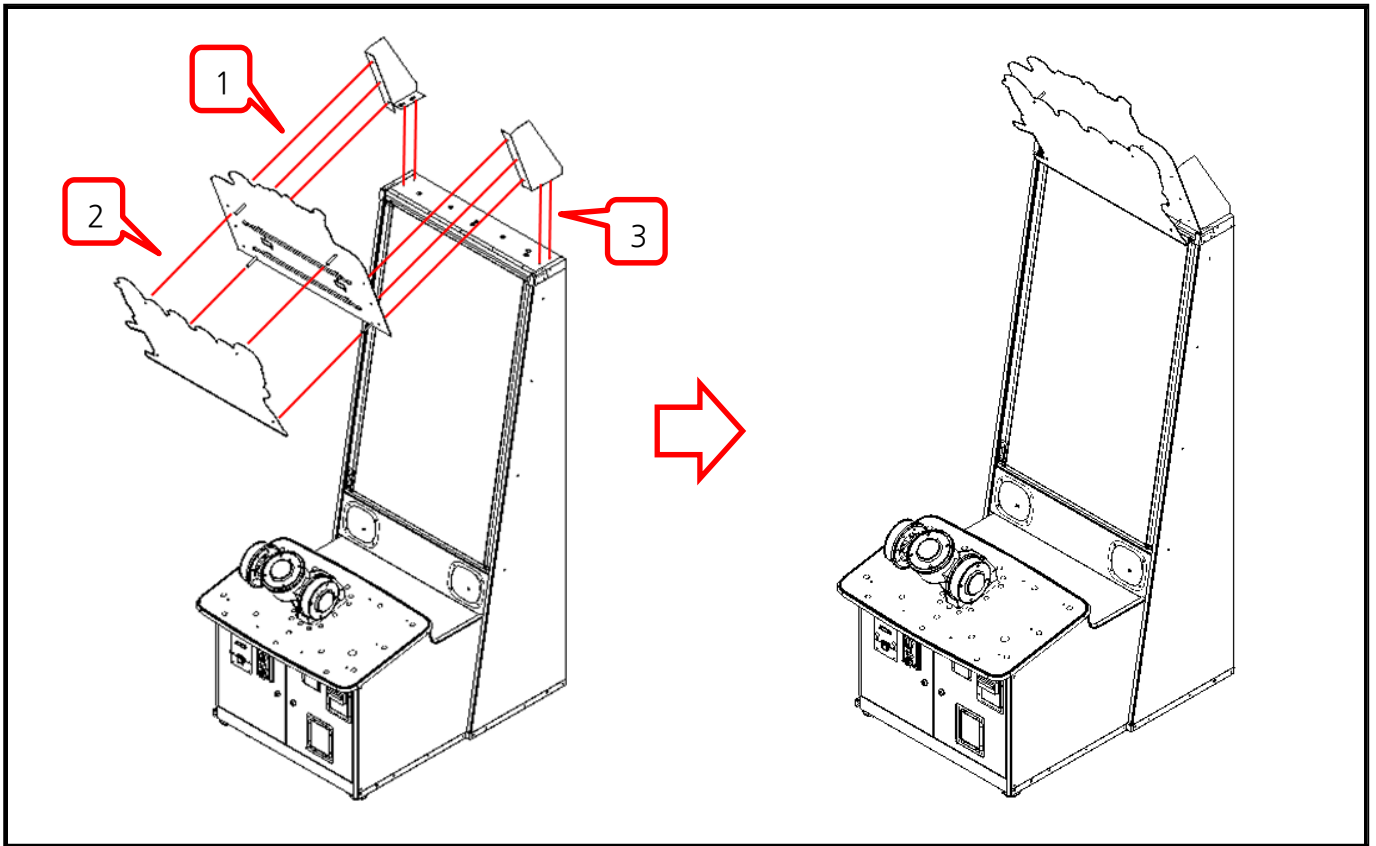

no	PROCESS	ITEM	Q'ty	BOLT	SPEC	Q'ty	NOTE
1	ASSEMBLE	BILLBOARD REAR ACRYL	1	TH_NI	4x12	6	
		BILLBOARD SIDE BKT - L, R	1	FLANGE NUT	M4	6	
2	ASSEMBLE	BILLBOARD FRONT ACRYL	1	TH_NI	4x8	4	
3	ASSEMBLE	BILLBOARD ASS'Y	1	SEMS	4x12	4	

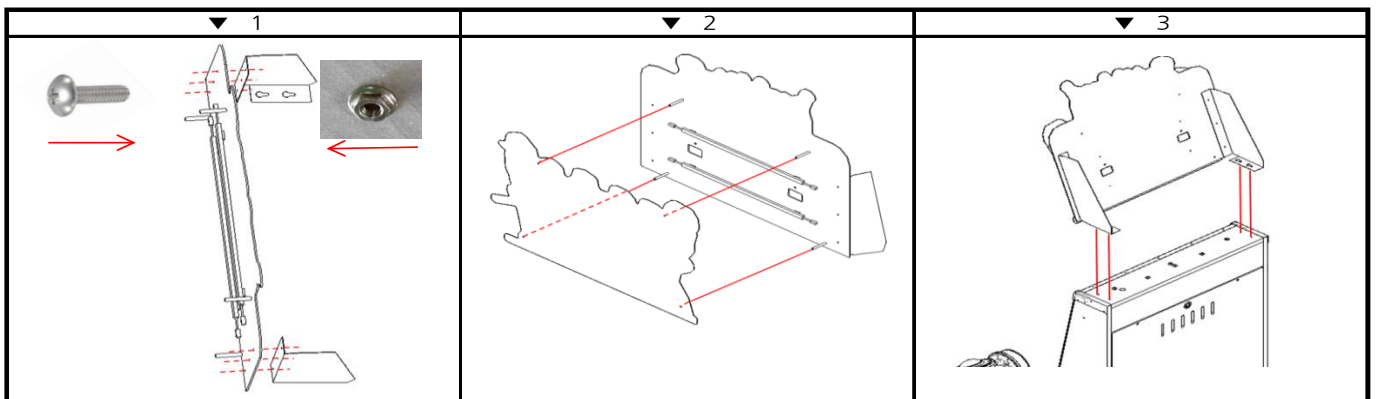

## 5 SETUP SETTINGS



### 1) SETUP BUTTON LAYOUT

NO	MODE	NOTE
1	SET-UP / UP	Setup menu mode, menu up move
2	SERVICE / SELECT	Normally service in, select and perform
3	- / DOWN	Menu down move
4	POWER	Power off/on switch
5	VOLUME	Volume control

### 2) MACHINE SETUP

NO	MODE	NOTE
1	TEST MODE	I/O treset, screen test
2	GAME SETTING	Game setting
3	CREDIT SETTING	credit setting
4	TICKET SETTING	Ticket setting
5	SOUND SETTING	Sound setting
6	BOOKKEEPING	Coins, emitted tickets
7	STATISTICS	Operation hours - machine play hours
8	LAGUAGE	ENGLISH / KOREAN
9	FACTORY SETTING	Factory reset
10	EXIT	Exit

### 3) TEST MODE

NO	MODE	NOTE
1	I/O TEST	Eeter to test game button, ticket dispenser, coin acceptor, light and etc.
2	SCREEN TEST	Enter to test the display.
3	EXIT	Return to MAIN SETUP MENU page.

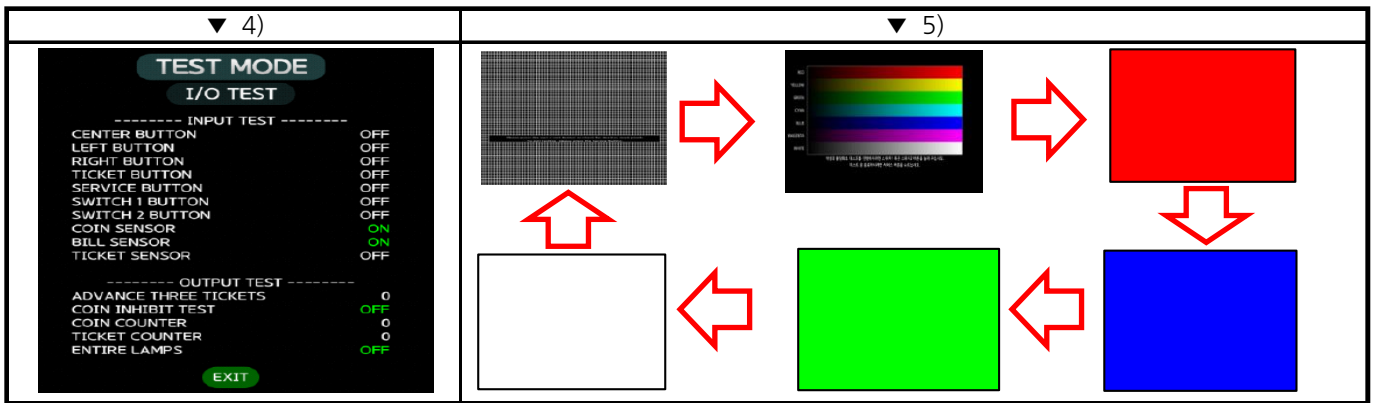

4) TEST MODE - I/O TEST

NO	MODE	NOTE
1	CENTER BUTTON	Game buton(Center) test: button press - on
2	LEFT BUTTON	Game button(Left) test: button press - on
3	RIGHT BUTTON	Game button(Right) test: button press - on
4	TICKET BUTTON	Ticket dispenser button: button press - on
5	SERVICE BUTTON	Setup button test: button press - on
6	SWITCH 1 BUTTON	Up button test: button press - on
7	SWITCH 2 BUTTON	Down button test: button press - on
8	COIN SENSOR	Coin sensor test: coin in - add counter
9	BILL SENSOR	Bill sensor test: bill in - add counter
10	TICKET SENSOR	Ticket sensor test: ticket out - on
11	ADVANCE THREE TICKETS	Ticket ejection test
12	COIN INHIBIT TEST	ON : Coin in(on), OFF: coin in(off)
13	COIN COUNTER	Coin in - increment by 1
14	TICKET COUNTER	Tickket ejection - increment by 1
15	ENTIRE LAMPS	Lamps test(game, ticket button, side, table light): on, off
16	EXIT	Exit

5) TEST MODE - SCREEN TEST

NO	MODE	NOTE
1	UP/DOWN BUTTON	Test for screen & output image on the monitor.
2	SERVICE BUTTON	Exit

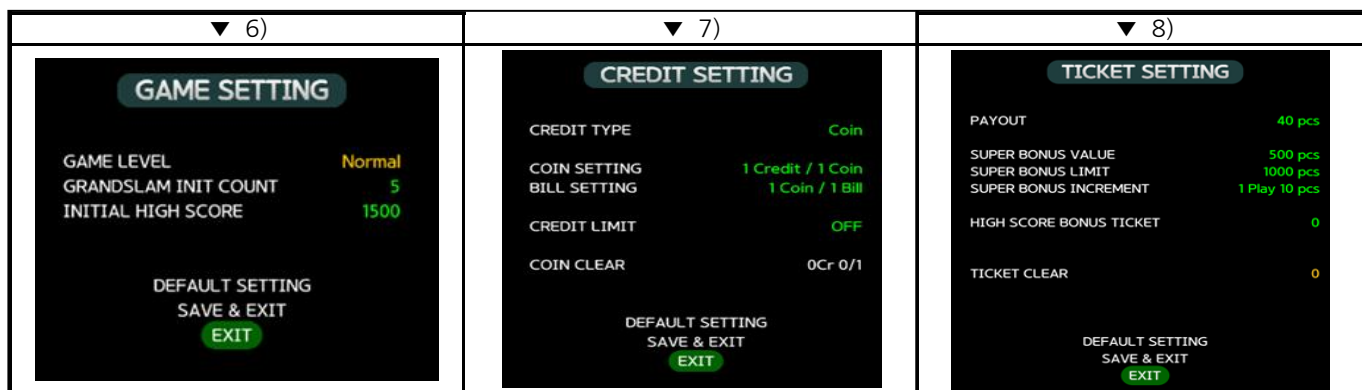

6) GAME SETTING

NO	MODE	NOTE	DEFAULT	RANGE
1	GAME LEVEL	Select: Easy - Normal - Hard	Normal	
2	GRANDSLAM INIT COUNT	Set the initial starting number of "GRAND SLAM" values	5	0 ~ 6
3	INITIAL HIGH SCORE	Initial high score setting, 100 unit increments	1500	1000 ~ 2000
4	DEFAULT SETTING	Set as default		
5	SAVE & EXIT	Save and Exit		
6	EXIT	Exit		

7) CREDIT SETTING

NO	MODE	NOTE	DEFAULT	RANGE
1	CREDIT TYPE	Select, coin/card	Coin	Coin / Card
2	COIN SETTING	Coin setup: 1 Credit / 1~9 Coin, 1~9 Credit / 1 Coin, Free play.	1/1	
3	BILL SETTING	Bill setup: 1 ~ 10 Coin / 1 Bill	1/1	
4	CREDIT LIMIT	Set the maximum amount of credits	OFF	OFF, 1 ~ 10
5	COIN CLEAR	Set the currently entered value to the initial value	0	
6	DEFAULT SETTING	Set as default		
7	SAVE & EXIT	Save and Exit		
8	EXIT	Exit		

8) TICKET SETTING

NO	MODE	NOTE	DEFAULT	RANGE
1	PAYOUT	Setting for PAYOUT	40	15~60
2	SUPER BONUS VALUE	Set "SUPER BONUS" value, adjust in 50 increments	500	50 ~ 3000
3	SUPER BONUS LIMIT	Set the maximum value of "SUPER BONUS". Adjust in 50 increments	1000	50 ~ 3000
4	SUPER BONUS INCREMENT	Set for "SUPER BONUS INCREMENT" per 1 play. Adjust in 1 increments	10	0 ~ 50
5	HIGH SCORE BONUS TICKET	Bonuses on High Score Renewal. 10 unit increments	0	10 ~ 300
6	TICKET CLEAR	Reset non-ejected tickets		
7	DEFAULT SETTING	Set as default		
8	SAVE & EXIT	Save and Exit		
9	EXIT	Exit		



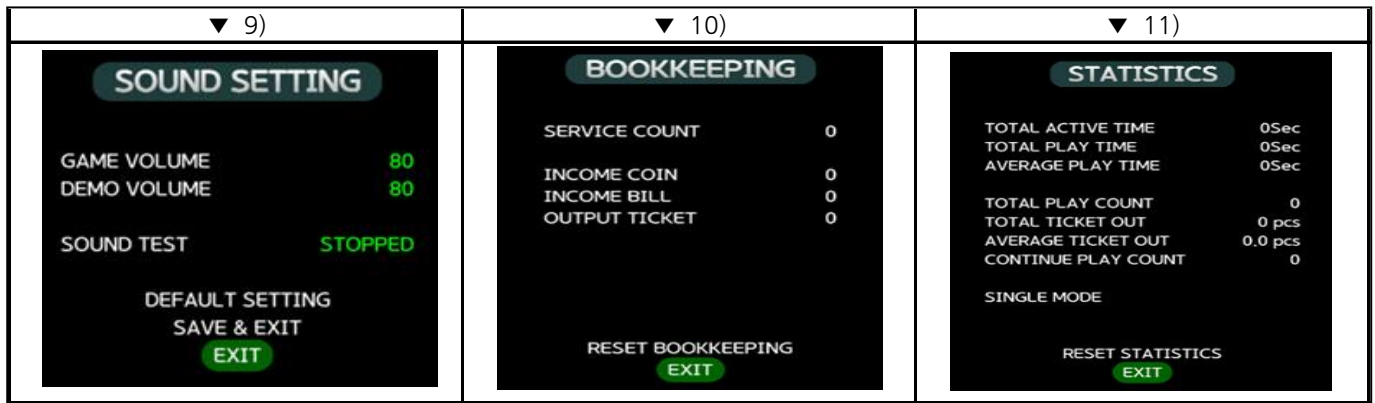

9) SOUND SETTING

NO	MODE	NOTE	DEFAULT	RANGE
1	GAME VOLUME	Game sound adjustment. 5 unit increments	80	0 ~ 100
2	DEMO VOLUME	Demo sound adjustment. 5 unit increments	80	0 ~ 100
3	SOUND TEST	Sound on. Off: sound reproduction for testing		
4	DEFAULT SETTING	Set as default		
5	SAVE & EXIT	Save and Exit		
6	EXIT	Exit		

10) BOOKKEEPING

NO	MODE	NOTE
1	SERVICE COUNT	Quantity increased by pressing the service button
2	INCOME COIN	Quantity of coins received
3	INCOME BILL	Quantity of bills received
4	OUTPUT TICKET	Number of tickets issued
5	RESET BOOKKEEPING DATA	Reset Bookkeeping data
6	EXIT	Exit

11) STATISTICS

NO	MODE	NOTE
1	TOTAL ACTIVE TIME	Power on ~ off time
2	TOTAL PLAY TIME	The accumulated time from the start of the game to the end of the game
3	AVERAGE PLAY TIME	Average game time
4	TOTAL PLAY COUNT	Accumulated play count
5	TOTAL TICKET OUT	The number of tickets accumulated through the game
6	AVERAGE TICKET OUT	Average number of tickets obtained per game
7	CONTINUE PLAY COUNT	Number of games replayed within 10 seconds
8	SINGLE MODE	SINGLE MODE
9	RESET STATISTICS	Reset STATISTICS data
10	EXIT	Exit

▼ 12)

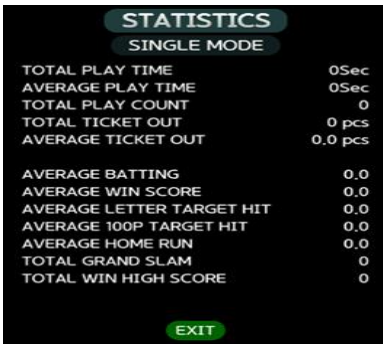

12) STATISTICS - SINGLE MODE

NO	MODE	NOTE
1	TOTAL PLAY TIME	The accumulated time from the start of the game to the end of the game
2	AVERAGE PLAY TIME	Average game time
3	TOTAL PLAY COUNT	Accumulated play count
4	TOTAL TICKET OUT	The number of tickets accumulated through the game
5	AVERAGE TICKET OUT	Average number of tickets obtained per game
6	AVERAGE BATTING	Average number of bets
7	AVERAGE WIN SCORE	Average Points Earned
8	AVERAGE LETTER TARGET	Average number of hits to characters
9	AVERAGE 100P TARGET H	Average number of hits 100 points
10	AVERAGE HOME RUN	Average number of home runs hit
11	TOTAL GRAND SLAM	Grand Slam cumulative number of times
12	TOTAL WIN HIGH SCORE	Number of times the highest score was updated
13	EXIT	Exit

## 6 MAINTENANCE

1) Precautions for turning on the power.

: When it is newly turned on after power is turned off, the power must be turned on after 10 seconds.

2) When installing the device

: Connect the device with a ground outlet to which fg is connected.

3) Basic product management : Clean it regularly

4) This product should only be used for indoor use

▼ 1)

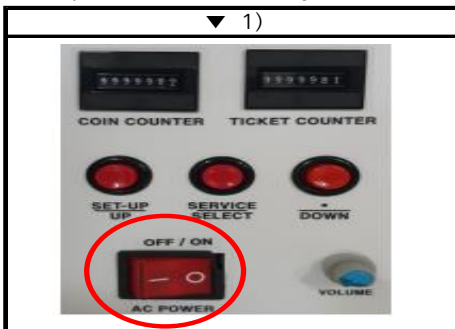

## 7 SOLUTION

### ► ERROR CODES

BOBBLEHEAD BASEBALL

CODE	ERROR	NOTE	PAGE
E.02	SYSTEM	Error of reading/writing on setup data	P14
E.03	SYSTEM	Setup data error	P14
E.11	COIN SELECTOR	Error of sensor from coin selector	
E.12	BILL ACCEPTOR	Error of sensor from bill acceptor	
E.21	COMMUNICATION ON BOARD	Error of connection on I/O board	P15
E.22	COMMUNICATION ON BOARD	Error of communication protocol version of I/O board	P16
E.23	COMMUNICATION ON BOARD	Error of connection code of I/O board	P16
	NO SIGNAL -MONITOR	MONITOR ERROR	P17
HELP	TICKET ERROR	Ticket dispensing error	

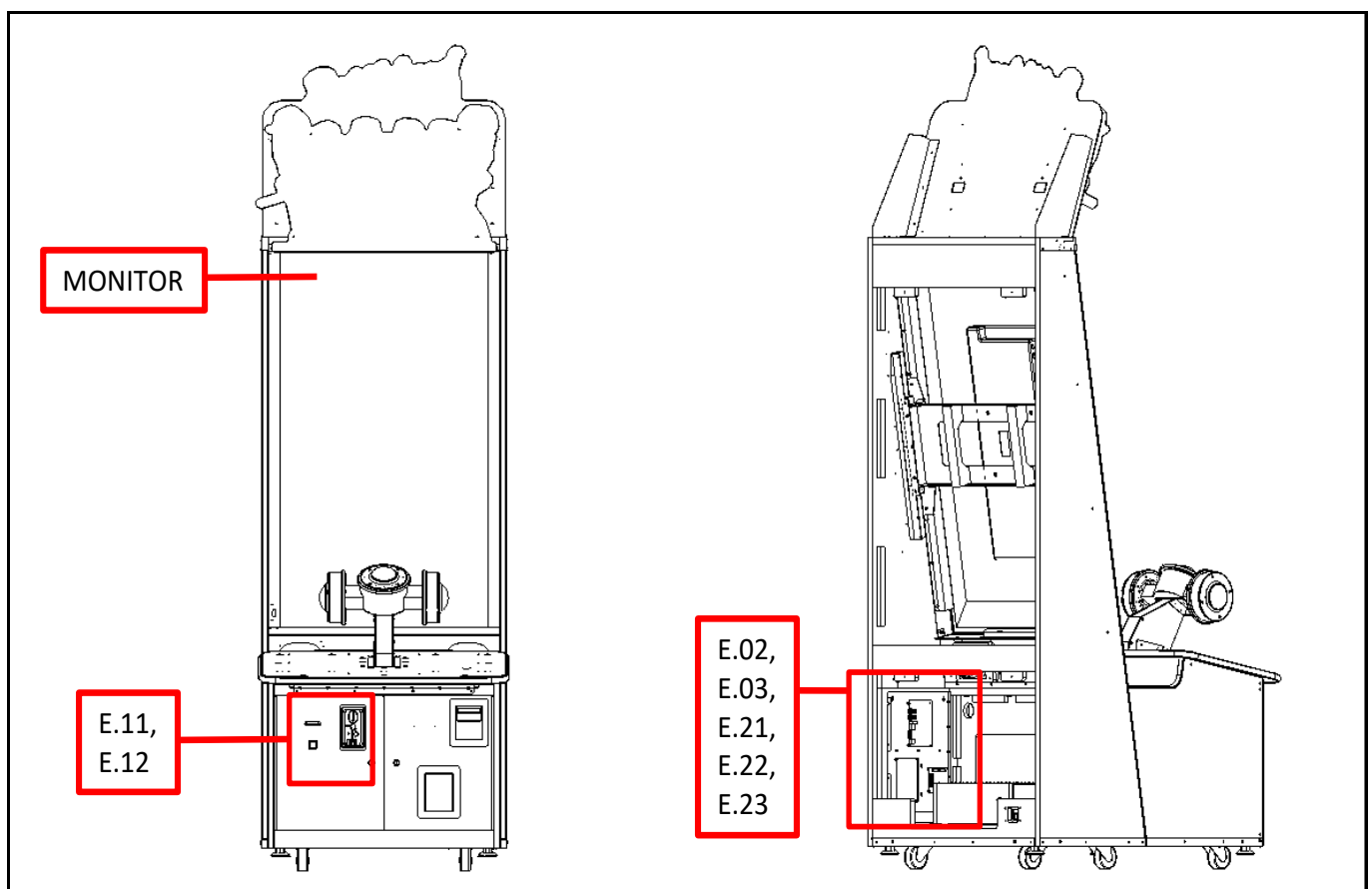

► TROUBLESHOOTING

1) SYSTEM DATA ERROR ( E.02 , E.03 )

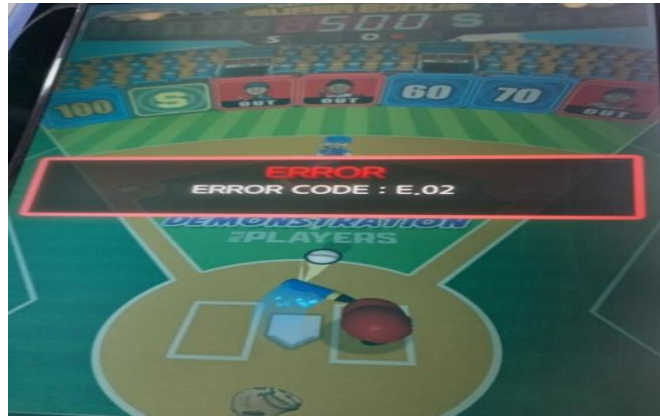
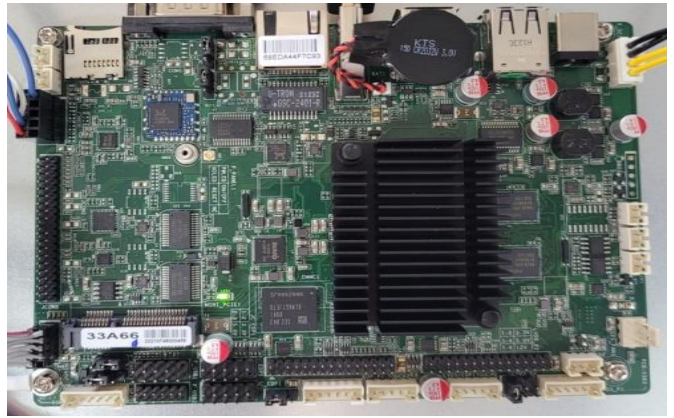
ERROR OR LOCATION	P1
	

► SOLUTION

1 HOW TO TEST POWER OFF → ON TEST

2 CHECK LIST

- 1) After turning the power off and on, check if the symptom appears.
- 2) ANDROID PCB REPLACEMENT ( P1 )

PART NAME	CODE	PART NAME	CODE
ANDROID PCB ASS'Y	ABHB0PCB001		

2) I/O CONNECTION ERROR ( E.21 )

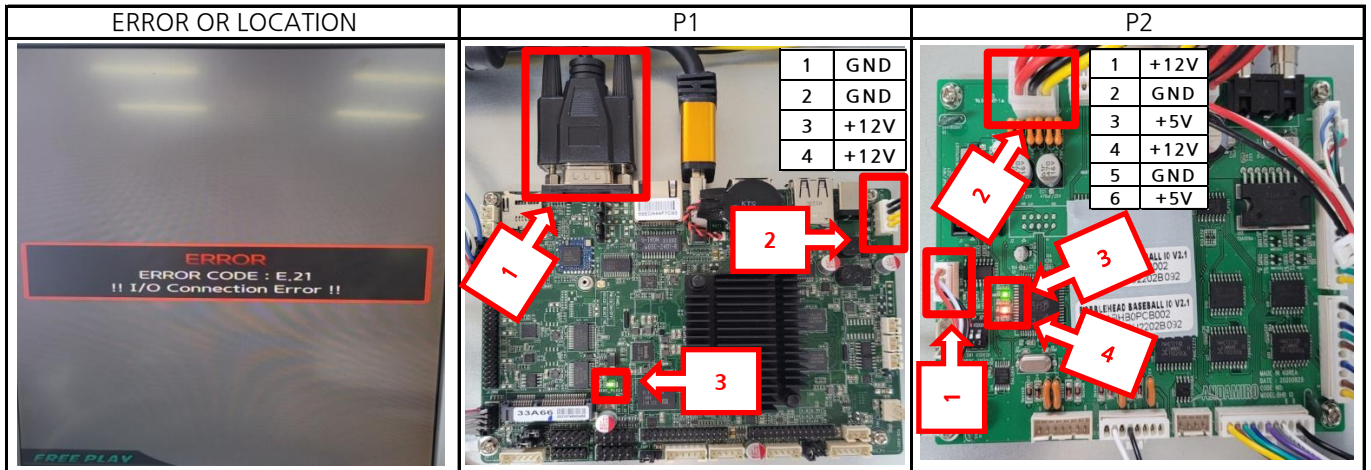



► SOLUTION

- 1 TEST : POWER OFF - ON TEST
- 2 CHECK : ANDROID
  - 1) Check and reconnect the D-SUB 9PIN connector ( P1-1 )
  - 2) Check DC IN connector connection status and reconector ( P1-2 )
  - 3) Check whether LED1 GREEN is on ( P1-3 )
  - 4) Power measurement ( P1-2 )
  - 5) ANDROID PCB REPLACEMENT
- 3 BHB I/O
  - 1) Check and reconnect CN7 UART0 3PIN connector ( P2-1 )
  - 2) Check the CN3 POWER connection status and reconector ( P2-2 )
  - 3) Check whether D2 GREEN is on ( P2-3 )
  - 4) Check whether D1 RED is blinking ( P2-4 )
  - 5) Power measurement ( P2-2)
  - 6) BHB I/O replacement

PART NAME	CODE	PART NAME	CODE
ANDROID PCB ASS'Y	ABHB0PCB001	BHB I/O PCB ASS'Y	ABHB0PCB002

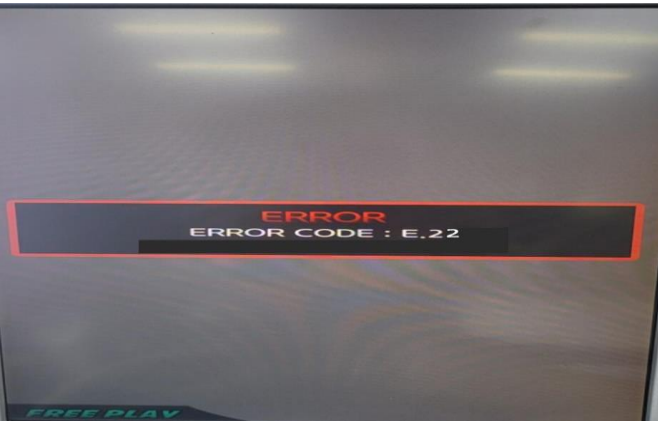
3) COMMUNICATION PROTOCOL ERROR ( E.22 ) / CODE CONNECTION ERROR ( E.23 )

ERROR OR LOCATION	P1
	

► SOLUTION

- 1 TEST : POWER OFF - ON TEST
- 2 CHECK :
  - 1) After turning the power off and on, check if the symptom appears.
  - 2) BHB I/O replacement ( P9 )

PART NAME	CODE	PART NAME	CODE
BHB I/O PCB ASS'Y	ABHB0PCB002		



4) MONITOR ERROR ( NO SIGNAL )

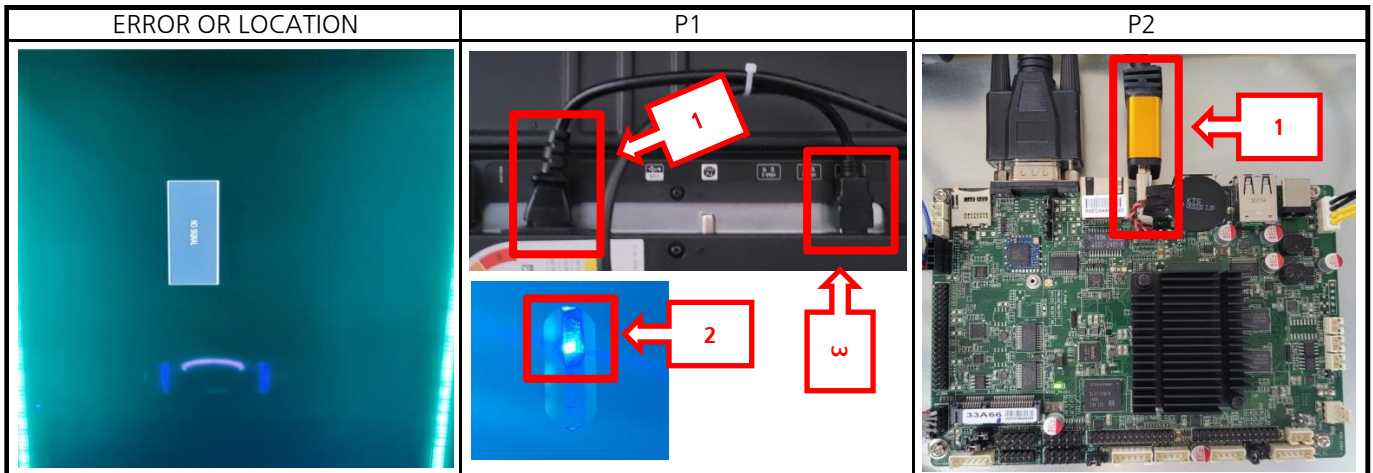

► SOLUTION

- 1 TEST : POWER ON TEST
- 2 CHECK : When nothing is displayed on the MONITOR screen
  - 1) After opening the door on the back of the product, check the power cable connected to the top of the monitor and reconnect it. ( P1-1 )
  - 2) Check if the LED at the bottom of the monitor on the front of the product is on. ( P1-2 )
  - 3) Check whether DISPLAY by connecting another monitor
  - 4) MONITOR replacement
- 3 CHECK : When NO SIGNAL is displayed on the MONITOR screen
  - 1) After opening the door on the back of the product, check the HDMI CABLE connected to the top of the monitor and reconnect it. ( P1-3 )
  - 2) Check the board connection status and reconnector( P2-1 )
  - 3) Check whether DISPLAY by connecting another monitor
  - 4) MONITOR replacement
  - 5) ANDROID replacement

PART NAME	CODE	PART NAME	CODE
LED 55' MONITOR	MZZZOLED002	ANDROID PCB ASS'Y	ABHB0PCB001



## 9 EXPLODED VIEW

### ► FULL DESCRIPTION

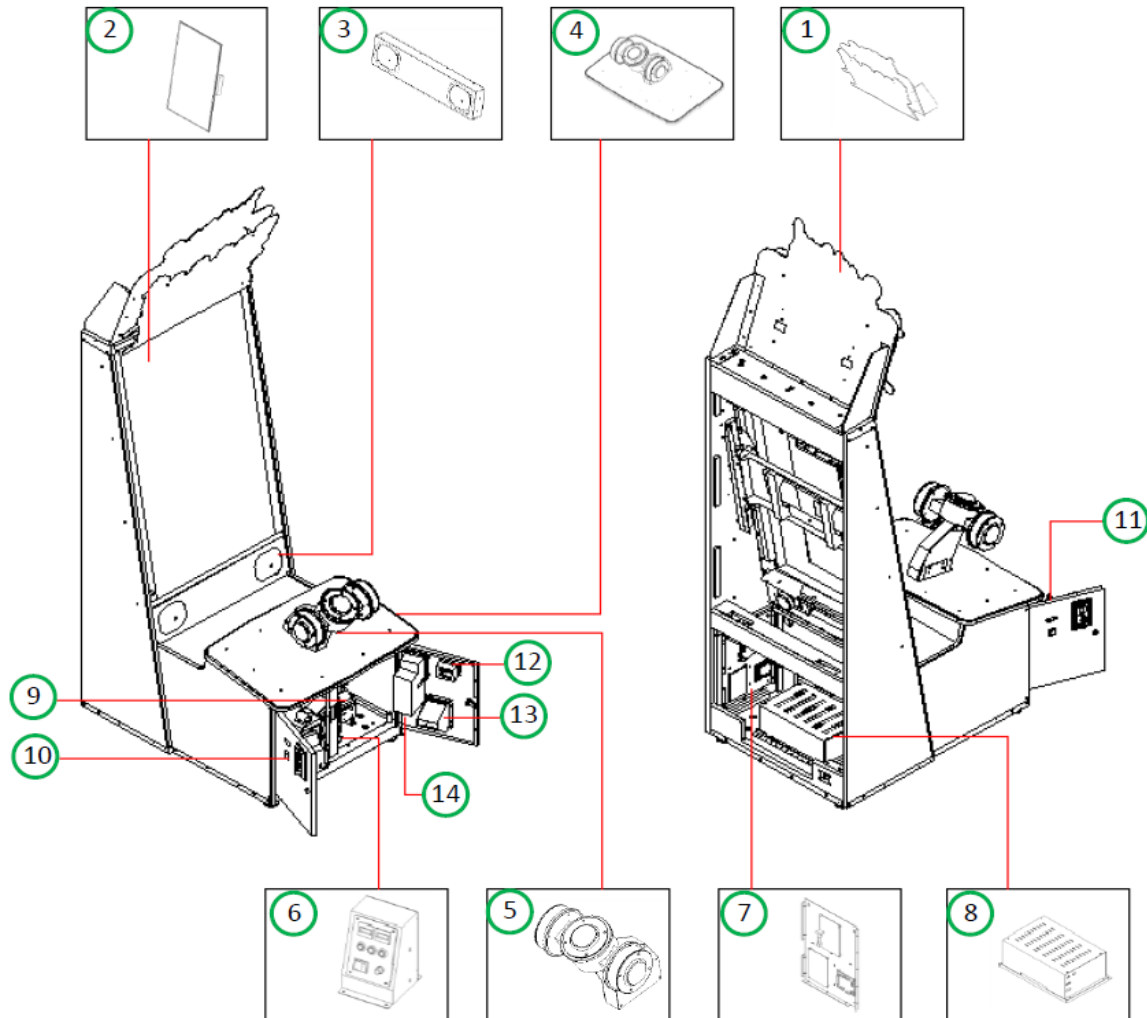

NO	PART NAME	Q'TY	PAGE	NO	PART NAME	Q'TY	PAGE
1	BILLBOARD PART	1		8	POWER SMPS BOX PART	1	
2	MONITOR PART	1		9	CARD DISPENSER(OPTION)	-	
3	SPEAKER PART	1		10	COIN SELECTOR(OPTION)	-	
4	TABLE PANEL PART	1		11	TICKET DISPENSER(OPTION)	-	
5	CONTROLLER PART	1		12	MEI ACCEPTOR RELAY(OPTION)	-	
6	SETUP PANEL PART	1		13	CARD OUTLET GUIDE(OPTION)	-	
7	MAIN PCB PART	1		14	BILL ACCEPT(OPTION)	-	

► DETAILED EXPLANATION

1) BILLBOARD PART

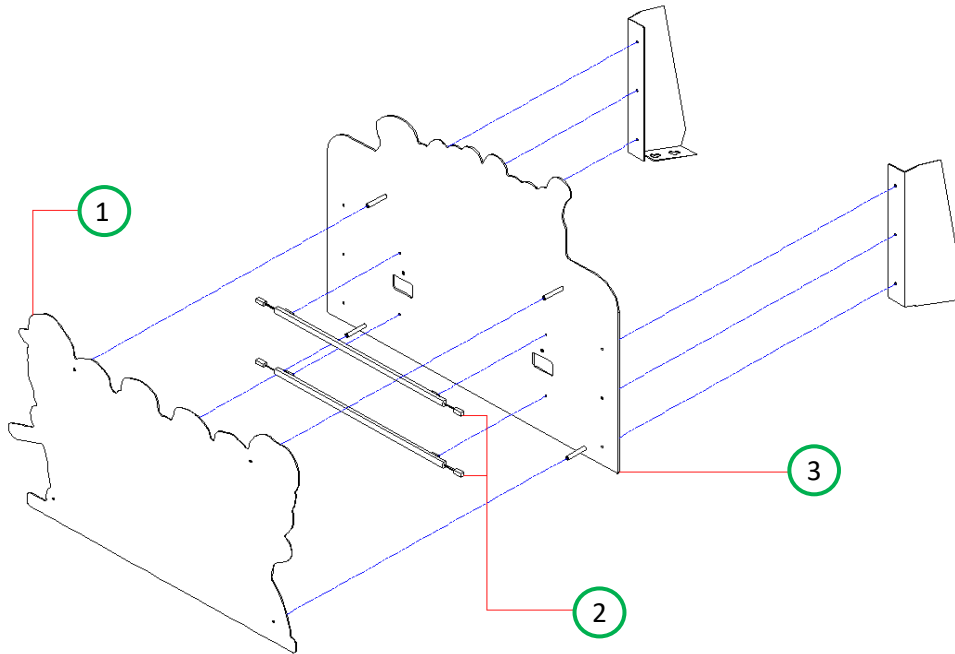

NO	PART NAME	SPEC.	Q'TY	CODE NO.
1	BILLBOARD FRONT ACRYL	-	1	ABHB0ACP006
2	12V LED BAR	460MM	2	AZZZ0PCB124
3	BILLBOARD REAR ACRYL	-	1	ABHB0ACP007

2) MONITOR PART

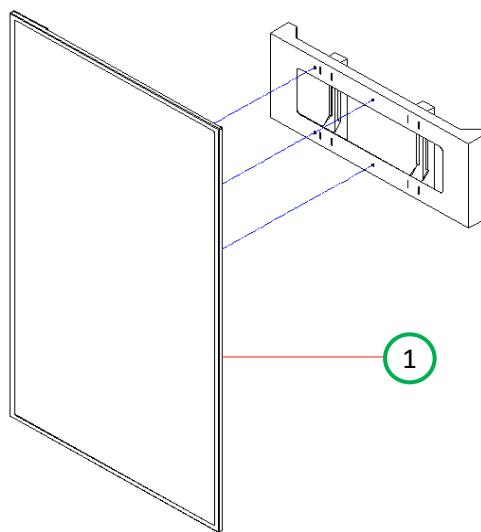

NO	PART NAME	SPEC.	Q'TY	CODE NO.
1	MONITOR	55INCH	1	MZZZ0LED002

3) SPEAKER PART

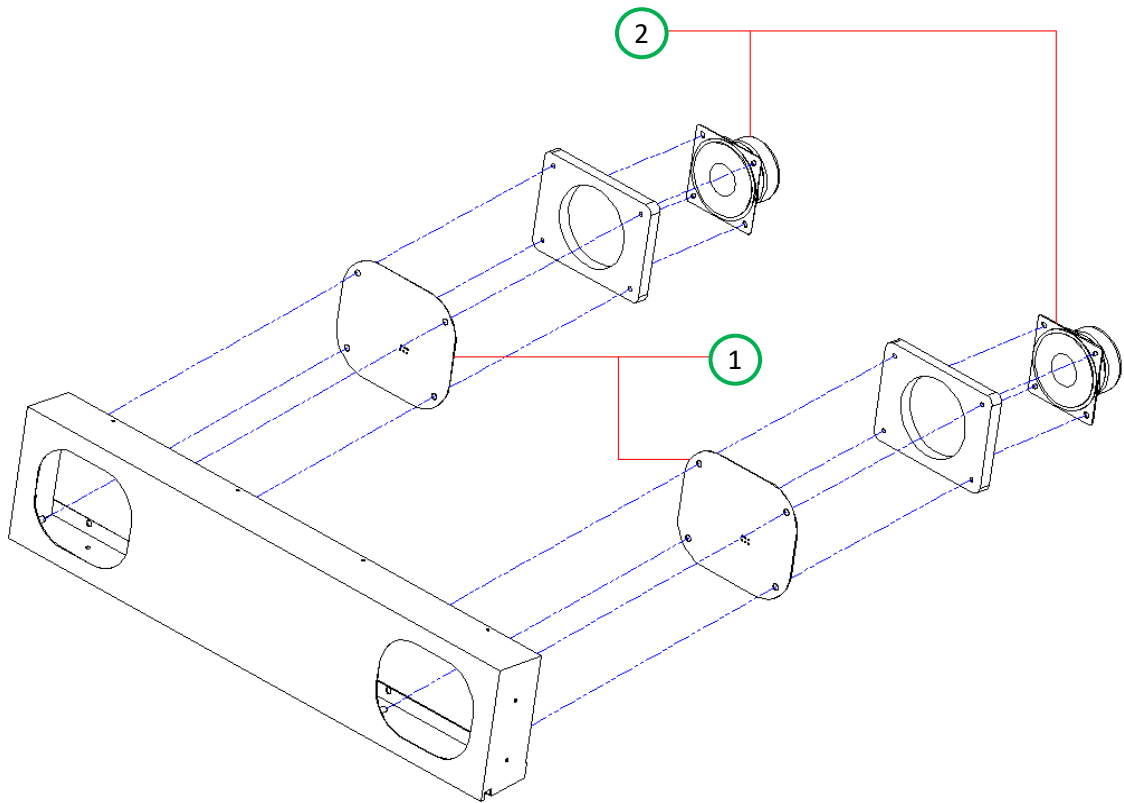

NO	PART NAME	SPEC.	Q'TY	CODE NO.
1	SPEAKER COVER MESH PLATE	PET 1.5t	1	MSBT0ACR038
2	SPEAKER	MID4.5"+TW1/2" 8OHM	2	MZZZOSPE021

4) TABLE PANEL PART

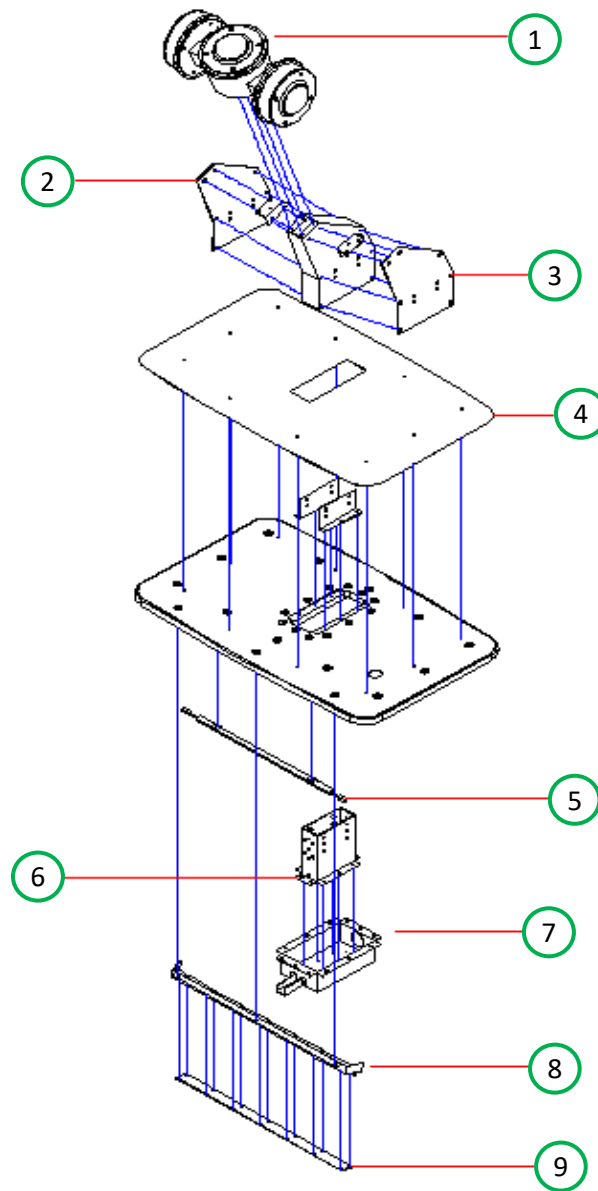

NO	PART NAME	SPEC.	Q'TY	CODE NO.
1	CONTROLLER	-	1	-
2	CONTROLLER SIDE ACRYL - L	ACRYL 3t	1	ABHB0ACP004
3	CONTROLLER SIDE ACRYL - R	ACRYL 3t	1	ABHB0ACP005
4	TABLE CONVER BKT	-	1	MBHB0MEP054
5	12V LED BAR	460MM	1	AZZZ0PCB124
6	CONTROLLER FRAME FIX CENTER BKT	-	1	-
7	CONTROLLER PLATE FIX BKT	-	1	-
8	FRONT TABLE LED COVER BKT	-	1	-
9	FRONT TABLE LED ACRYL	-	1	MBHB0ACR005

5) CONTROLLER PART

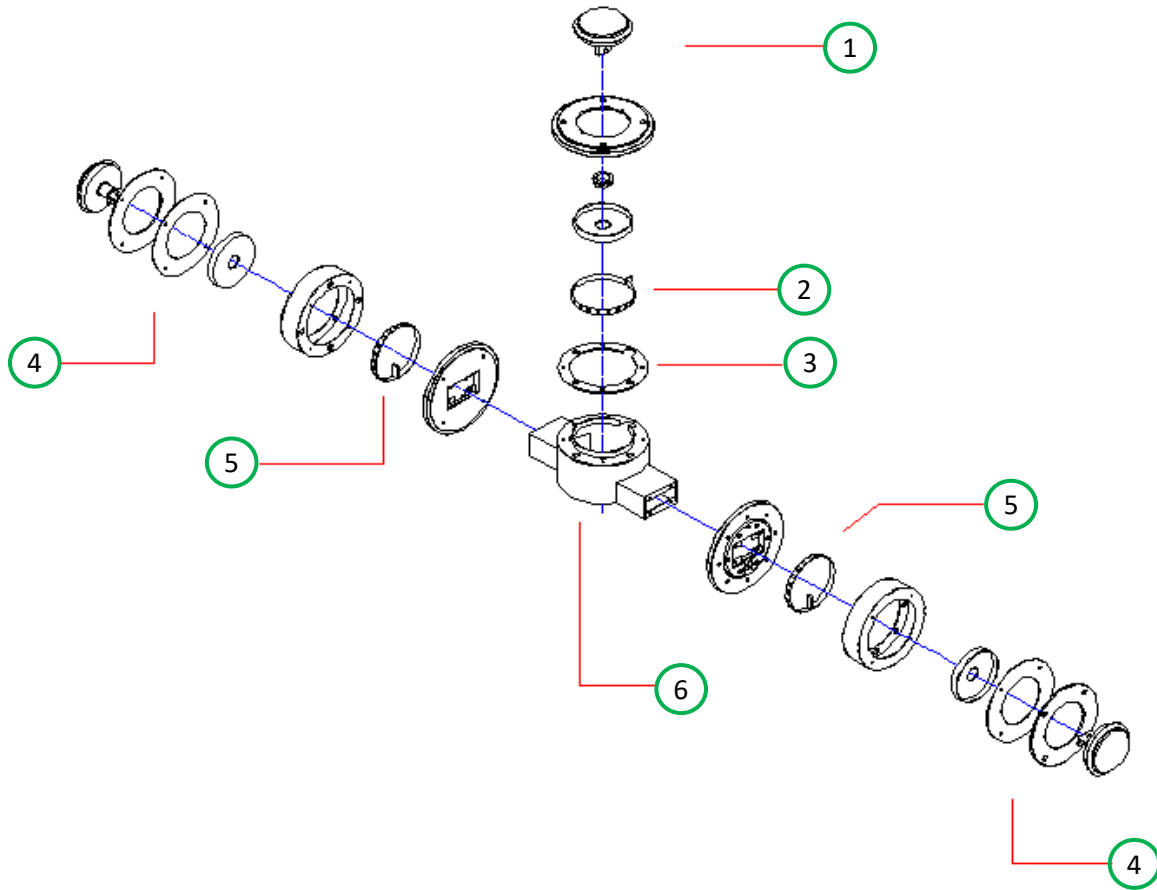

NO	PART NAME	SPEC.	Q'TY	CODE NO.
1	ASS'Y-CENTER BUTTON	-	1	-
2	CONTROLLER CENTER BUTTON LED	-	1	-
3	CENTER BUTTON SUP PET	-	1	MBHB0ACR004
4	BUTTON ASS'Y	CWB 401	2	MZZZ0BUT080
5	BUTTON WHEEL ASS'Y	-	2	-
6	BUTTON CENTER FIX BKT	-	1	-

6) SETUP PABEL PART

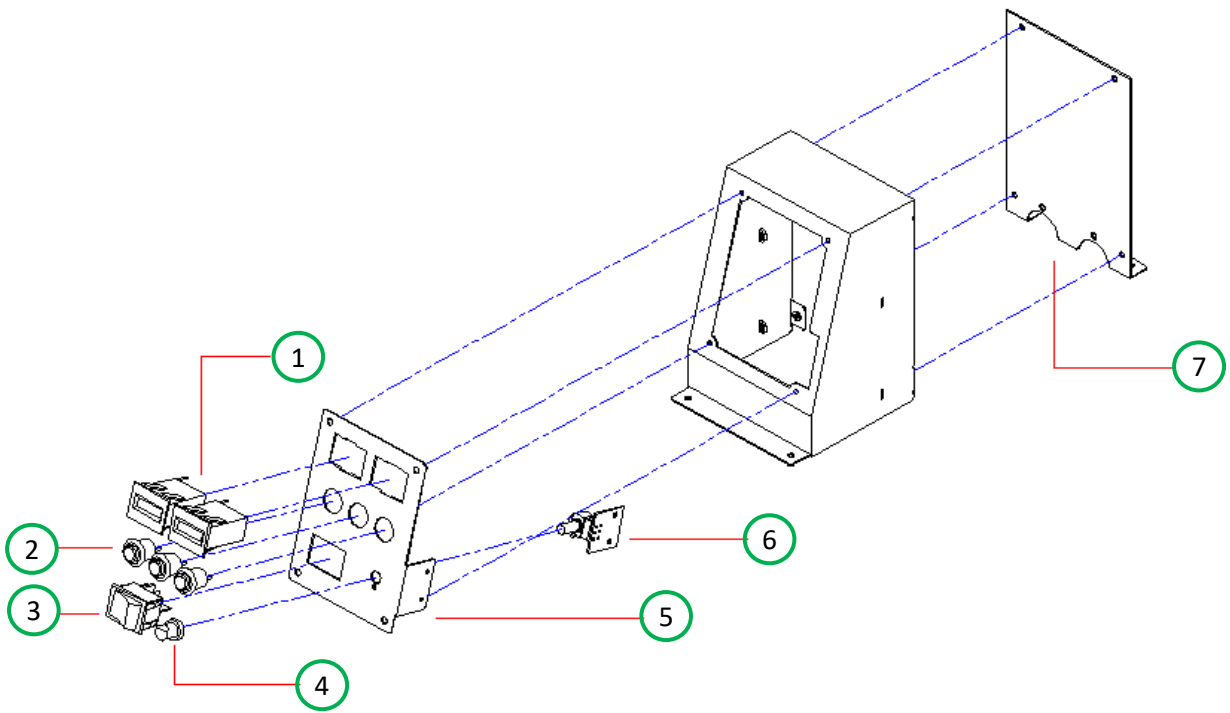

NO	PART NAME	SPEC.	Q'TY	CODE NO.
1	COUNTER	OA127CL W/2P	1	MZZZ0COU002
2	PUSH BUTTON SWITCH	DS412R	2	MELE0PUS006
3	ROCKER SWITCH	R595KDF	4	MELE0SWI021
4	VOLUME KNOB	CAP BLUE	1	MELE0VOL007
5	SETUP PANEL	-	1	MBHB0MEP050
6	BOLUME PCB	-	1	AHM20PCB016
7	SETUP PANEL COVER	-	1	-

7) MAIN PCB PART

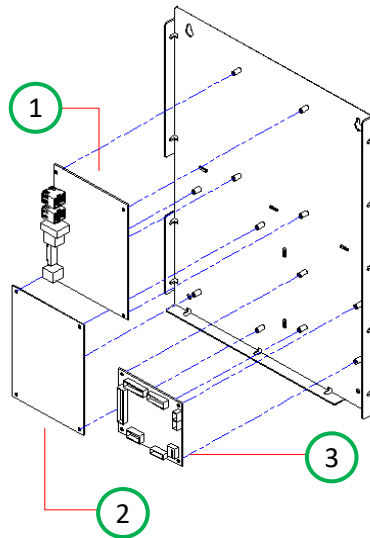

NO	PART NAME	SPEC.	Q'TY	CODE NO.
1	VIDEO IO BOARAD PCB	-	1	ABHB0PCB001
2	MAIN BOARD IO PCB	-	1	ABHB0PCB002
3	IO PCB	-	1	AZZZ0PCB 185

8) POWER SMPS BOX PART

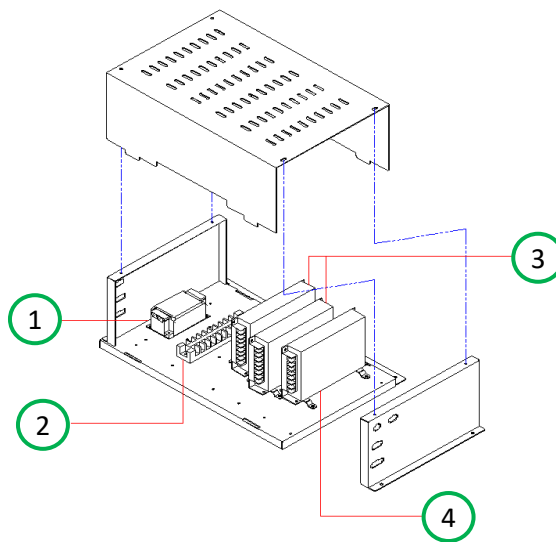

NO	PART NAME	SPEC.	Q'TY	CODE NO.
1	NOISE FILTER	RNS-2010	1	MELE0NOI009
2	TERMINAL BLOCK	250V 10P UL_CE	1	MELE0TEB003
3	POWER SMPS	LRS-150F-12	2	MELE0SMP090
4	POWER SMPS	LRS-150F-5	1	MELE0SMP095



## 10 PCB CONNETCOR LOCATION

※ The arrow point means the contact pin number 1.

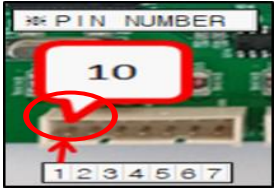
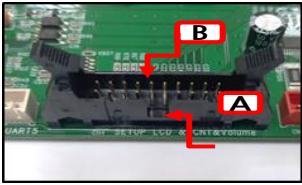
1	2	pin description
		1. The arrow point means the contact pin number 1. 2. direction of Hirose connector

### 1) BHB IO PCB ASS'Y

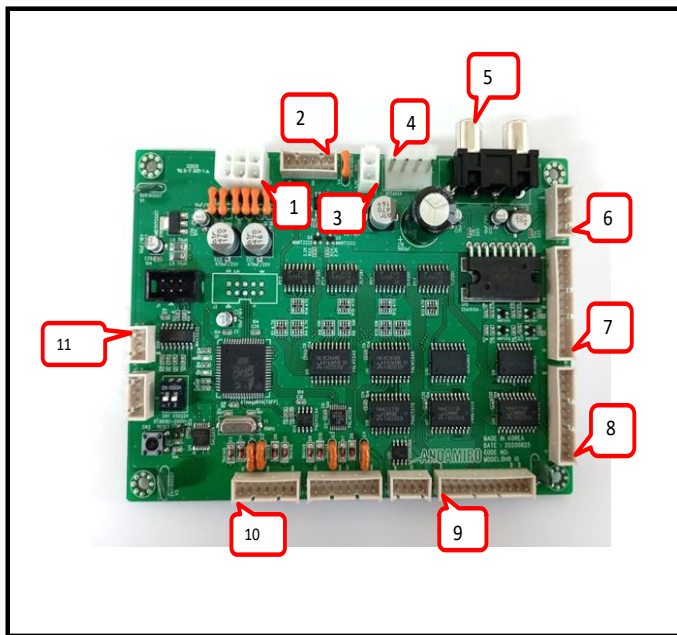

no	FUNCTION	LOCATION	PIN
1	POWER 12V, 5V	CN3	6
2	COIN	CN9	6
3	SPEAKER POWER 12V	CN13	2
4	SPEAKER	CN2	4
5	AUDIO	RCA1	2
6	VOLUME	CN13	5
7	TICKET	CN6	12
8	SETUP/COUNTER	CN4	10
9	BTN_LAMP	CN5	11
10	BILL	CN10	8

### 2) ANDROID MAIN PCB ASS'Y

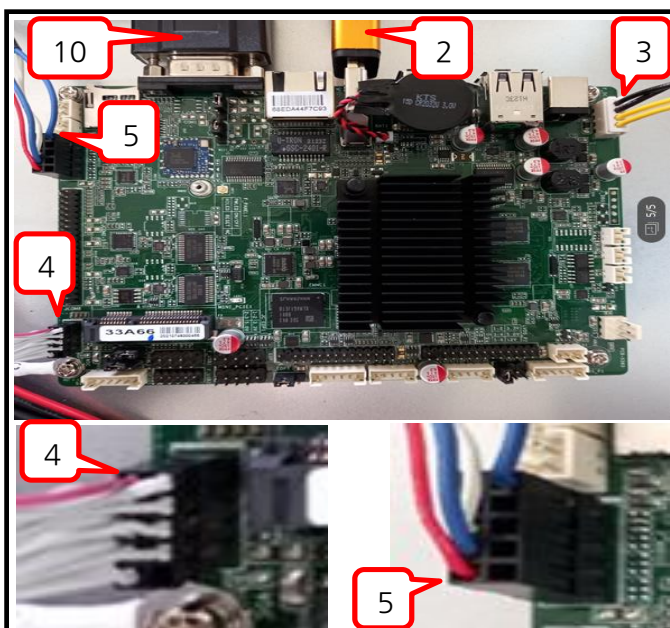

no	FUNCTION	LOCATION	PIN
1	D-SUB UART(IO PCB)	COM1	6
2	HDMI(MONITOR)	CN2	3
3	POWER 12V	F_DCIN1	4
4	RS232(WS2813B IO PCB)		9
5	F_AUDIO(IO PCB)		9

3) WS2813B IO PCB ASS'Y

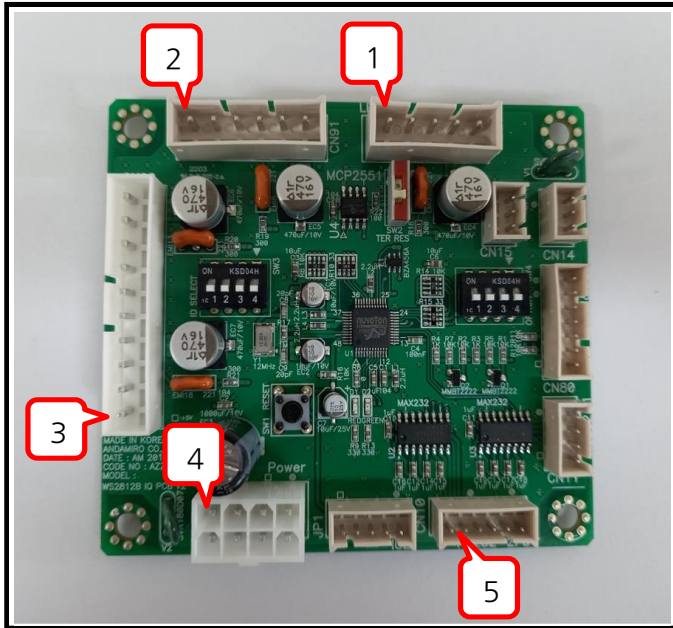

no	FUNCTION	LOCATION	PIN
1	LED - SIDE LEFT	LED1	5
2	LED - SIDE RIGHT	LED2	6
3	LED - CONTROL	LED3	10
4	POWER 5V	POWER	8
5	RS232(MAIN PCB)	JP10	6

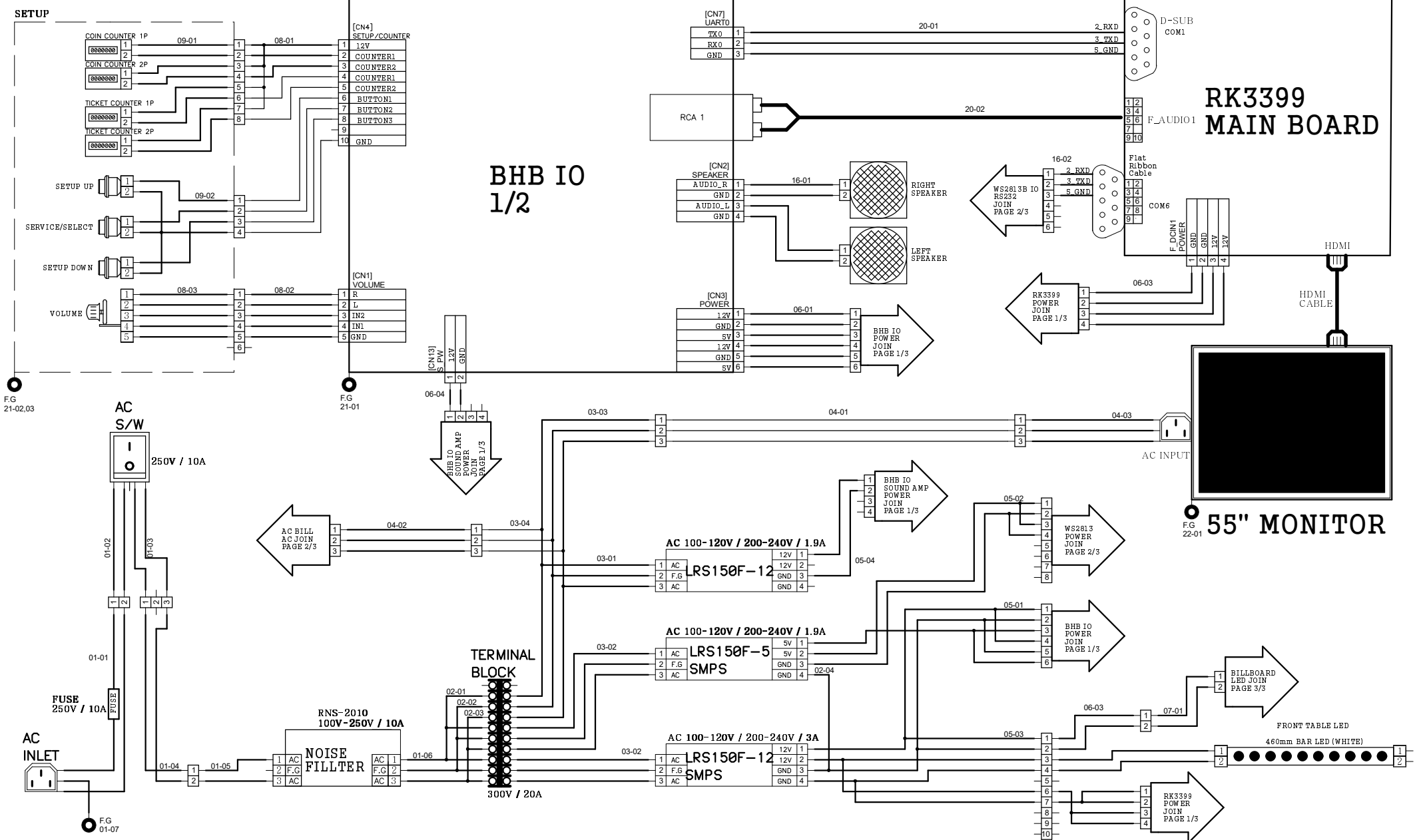

REPRODUCTION, DISTRIBUTION AND UTILIZATION OF THIS DOCUMENT AS WELL AS COMMUNICATION OF ITS CONTENTS TO OTHERS WITHOUT EXPRESS AUTHORIZATION PROHIBITED. OFFENDERS WILL BE HELD LIABLE FOR THE PAYMENT OF DAMAGES. ALL RIGHT RESERVED. COPYRIGHT (c) ANDAMIRO

(복제, 배포 및 사용은 물론, 명시적 허가 없이는 타인에게 내용을 전달할 수 없으며 위반자는 손해 배상 책임을 집니다.)

DEPARTMENT	DRAWN BY	CHECKED BY	APPROVED BY	ITEM
H/W	E.S.KIM			BOBBLE HEAD BASEBALL
				PAGE 1 of 3
				DATE 2022.01.24



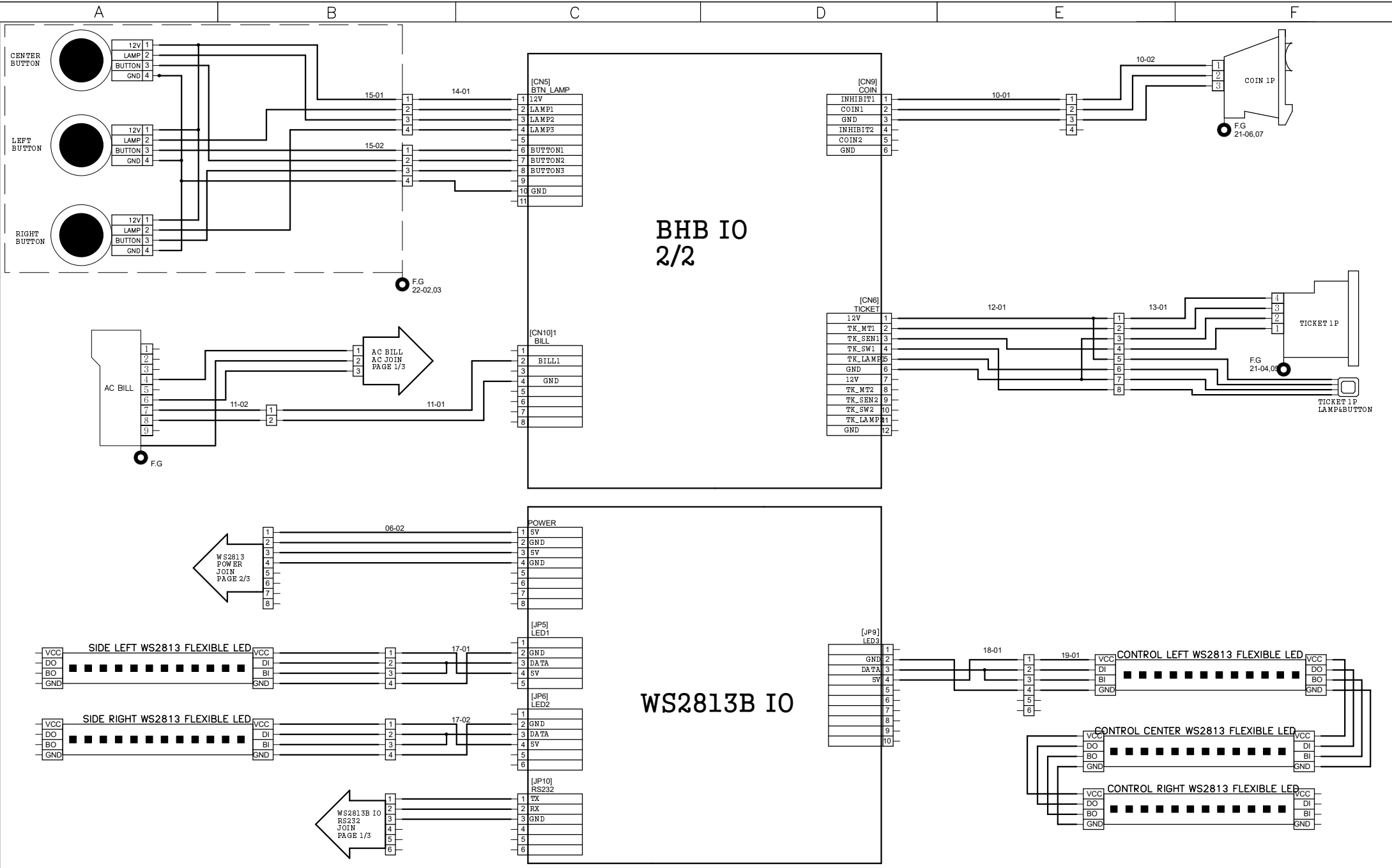

## BHB IO 2/2

## WS2813B IO

REPRODUCTION, DISTRIBUTION AND UTILIZATION OF THIS DOCUMENT AS WELL AS COMMUNICATION OF ITS CONTENTS TO OTHERS WITHOUT EXPRESS AUTHORIZATION PROHIBITED. OFFENDERS WILL BE HELD LIABLE FOR THE PAYMENT OF DAMAGES. ALL RIGHT RESERVED. COPYRIGHT (c) ANDAMIRO

(복제, 배포 및 사용은 물론, 명시적 허가 없이는 타인에게 내용을 전달할 수 없으며 위반자는 손해 배상 책임을 집니다.)

DEPARTMENT	DRAWN BY	CHECKED BY	APPROVED BY	ITEM	BOBBLE HEAD BASEBALL
H/W	E.S.KIM			PAGE	2 of 3
				DATE	2022.01.24



# BILLBOARD LED

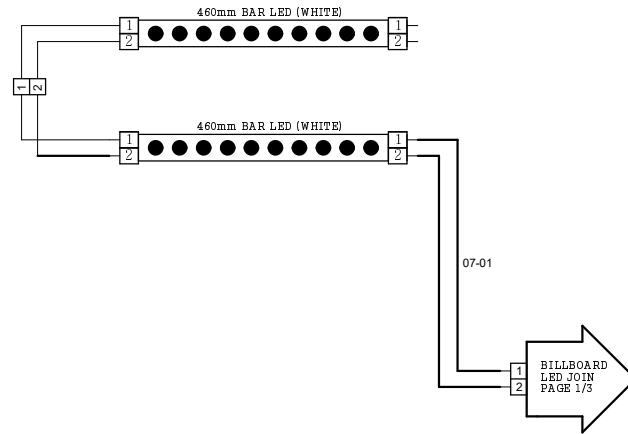

REPRODUCTION, DISTRIBUTION AND UTILIZATION OF THIS DOCUMENT AS WELL AS COMMUNICATION OF ITS CONTENTS TO OTHERS WITHOUT EXPRESS AUTHORIZATION PROHIBITED. OFFENDERS WILL BE HELD LIABLE FOR THE PAYMENT OF DAMAGES. ALL RIGHT RESERVED. COPYRIGHT (c) ANDAMIRO

(복제, 배포 및 사용은 물론, 명시적 허가 없이는 타인에게 내용을 전달할 수 없으며 위반자는 손해 배상 책임을 집니다.)

DEPARTMENT	DRAWN BY	CHECKED BY	APPROVED BY	ITEM	BOBBLE HEAD BASEBALL
H/W	E.S.KIM			PAGE	3 of 3
				DATE	2020.09.21



## **ANDAMIRO WARRANTY POLICY**



Andamiro warrants to the original purchaser that all of its products will be free from defects in material and workmanship.

**Andamiro warrants the parts from date of shipment as follows.**

**- One Year Limited Warranty : Electronic Boards & Monitor**

For any key components within the warranty period, Andamiro will repair or replace defective components free of charge.

When placing a warranty request, the customer is requested to furnish the following information:

1. Name of the game.
2. Serial Number of the game.
3. A Detailed Description of the defect/s experienced.

This warranty does not apply to the defects caused due to misuse or abuse of the product.

Any alterations made to game or game parts will void this warranty.

For warranty details on our product range please visit our website, [www.andamiro.com](http://www.andamiro.com).

ANDAMIRO CO., LTD.  
[www.andamiro.com](http://www.andamiro.com)



Please complete the following request form to place a warranty request and send it to ANDAMIRO Korea either by fax (Fax No: +82-31-908-7548) or by e-mail. The e-mail address of the person in charge of each region is shown in our web-site, [www.andamiro.com](http://www.andamiro.com)

For the on-line request, please visit our web-site, [www.andamiro.com](http://www.andamiro.com) and click "Customer Service" and then click "Contact Us" in which you shall find the e-mail address of the person in charge of each region.

**1. Company Name :** \_\_\_\_\_

**2. Mailing Address :** \_\_\_\_\_

\_\_\_\_\_

**3. E-Mail Address :** \_\_\_\_\_

**4. Phone No :** \_\_\_\_\_

**5. Name of the person in charge :** \_\_\_\_\_

**6. Description of the product defects**

6-1 ) Name of the Game : \_\_\_\_\_

6-2 ) Serial No : \_\_\_\_\_

6-3 ) Date of Purchase : \_\_\_\_\_

6-4 ) Detailed description of the product defects.

\_\_\_\_\_

\_\_\_\_\_

\_\_\_\_\_

Remarks: If possible, please provide us with related photos and videos which will be greatly appreciated to verify the cause of the problem.



---

**ANDAMIRO CO., LTD.**

TEL : 82-31-909-2123~5

**[ADDRESS OFFICE]** 704-1 Techno Town, 138, Ilsan-ro, Ilsandong-gu, Goyang-si,  
Gyeonggi-do, Republic of Korea 10442

**[FACTORY]** 72 Nochemgil, Ilsan-donggu Goyang-si, Gyonggi-do, 410-834 korea

**USA BRANCH**

ANDAMIRO USA CORP.

TEL : 1-310-767-5800

**[ADDRESS]** 2222 Century Cir, Irving TX 75062 U.S.A

Homepage <http://www.andamiro.com/>